

Industrial Barcode Printer

# ML241P Series

Thermal Transfer • Direct Thermal

## Series Models

ML241P / ML341P



**User Manual**

# Copyright

©2024 TSC Auto ID Technology Co., Ltd.

The copyright in this manual, the software and firmware in the printer described are owned by TSC Auto ID Technology Co., Ltd. All rights reserved.

CG Triumvirate is a trademark of Agfa Corporation. CG Triumvirate Bold Condensed font is under license from the Monotype Corporation. Windows is a registered trademark of Microsoft Corporation.

All other trademarks are the property of their respective owners. Information in this document is subject to change without notice and does not represent a commitment on the part of TSC Auto ID Technology Co. No part of this manual may be reproduced or transmitted in any form or by any means, for any purpose other than the purchaser's personal use, without the expressed written permission of TSC Auto ID Technology Co.



# Contents

- 1 Introduction ..... 3**
  - 1.1 Product Specification.....4
- 2 Unpacking and Inspecting..... 7**
- 3 Getting to Know Your Printer ..... 8**
  - 3.1 Front View .....8
  - 3.2 CInner View.....9
  - 3.3 Rear View..... 10
- 4 Operator Interface..... 11**
  - 4.1 LED Indicator..... 12
  - 4.2 Keypads ..... 12
  - 4.3 Icon Indicators ..... 13
  - 4.4 Power-on Utilities ..... 14
  - 4.5 Web User Interface ..... 16
- 5 Setting up the Printer..... 22**
  - 5.1 Connecting the Power Cable.....22
  - 5.2 Loading the Ribbon .....23
  - 5.3 Loading the Media.....25
  - 5.4 Loading the Fanfold Media.....27
  - 5.5 Loading the Media in Peel-off Mode (Optional) .....28
  - 5.6 Loading the Media in Cutter Mode (Optional).....30
- 6 Adjustment Knobs ..... 32**
  - 6.1 Printhead Pressure Adjustment Knob.....32
  - 6.2 Ribbon Tension Adjustment Knob.....33
  - 6.3 Mechanism Fine Adjustment to Avoid Ribbon Wrinkles.....34

<b>7</b>	<b>TSC Console.....</b>	<b>36</b>
7.1	Starting TSC Console.....	36
7.2	Adding the Ethernet Interface.....	38
7.3	Set Wi-Fi and Add to TSC Console Interface .....	40
7.4	Initialize the Printer Wi-Fi Setting .....	43
7.5	TPH Care .....	44
7.6	Printer Function .....	45
7.7	Setting Post-Print Action.....	46
<b>8</b>	<b>Printer Configuration .....</b>	<b>47</b>
8.1	Setting .....	48
8.2	Sensor.....	55
8.3	Interface .....	57
8.4	Advanced .....	60
8.5	File Manager .....	62
8.6	Diagnostic .....	63
8.7	Favorites .....	65
<b>9</b>	<b>Troubleshooting.....</b>	<b>67</b>
<b>10</b>	<b>Maintenance .....</b>	<b>70</b>
<b>11</b>	<b>Agency Compliance and Approvals .....</b>	<b>72</b>
	<b>Revision History.....</b>	<b>80</b>

# 1 Introduction

Thank you very much for purchasing TSC barcode printer.

The compact ML241P Series, perfect for height-restricted applications like rack-mounting, supports up to 8-inch O.D. label rolls for high-volume printing and increased uptime. Its intuitive design simplifies the user experience, allowing for easy adjustment of the thermal printhead (TPH) pressure and ribbon tension balance, ensuring optimal printing quality. Toolless TPH and platen roller removal expedite maintenance, while TSC sense care prevents operational downtime with self-diagnostic features.

The printer capabilities are designed with auto-switching emulation for hassle-free deployment. Plus, TSC Standalone Creator generates a printer LCD UI for quick template access, while TSCPRTGo turns a mobile device into an extended display for mobile printing. SOTI Connect, TSC Console, and the Internal Embedded Webpage enable remote fleet management.

Additionally, this eco-friendly printer boasts 100% recyclable packaging and casing, with over 90% recyclable components, minimizing its environmental impact.

This document provides an easy reference for operating this printer. TSC printers include the Windows labeling software for creating your label template. For system integration, the TSPL/TSPL2 printer programming manual or SDKs can be found on TSC website at: <https://www.tscprinters.com>.

## 1.1 Product Specification

Model	ML241P	ML341P
<b>Resolution</b>	8 dots/mm (203 dpi)	12 dots/mm (300 dpi)
<b>Print Method</b>	Thermal Transfer & Direct Thermal	
<b>Max. Print Speed</b>	204 mm (8") /second	152 mm (6") /second
<b>Max. Print Width</b>	108 mm (4.25")	105.7 mm (4.16")
<b>Max. Print Length</b>	25,400 mm (1,000")	11,430 mm (450")
<b>Enclosure</b>	Die-cast based print mechanism & Metal cover with large clear media view window	
<b>Physical Dimension</b>	248 mm (W) x 245 mm (H) x 416 mm (D) 9.76" (W) x 9.65" (H) x 16.38" (D)	
<b>Weight</b>	7.7 kg (16.98 lbs.)	
<b>Label Roll Capacity</b>	203.2 mm (8") outside diameter; 1" or 3" inside diameter core	
<b>Ribbon</b>	450 m with 1" ribbon core (inside diameter); ink coated outside or inside	
<b>Ribbon Width</b>	40 – 110 mm (1.6" – 4.3")	
<b>Processor</b>	32-bit RISC CPU	
<b>Memory</b>	<ul style="list-style-type: none"> <li>▪ 128 MB Flash memory</li> <li>▪ 128 MB SDRAM</li> </ul>	
<b>I/O &amp; Connectivity</b>	<ul style="list-style-type: none"> <li>▪ RS-232</li> <li>▪ USB 2.0</li> <li>▪ Ethernet (10/100 Mbps)</li> <li>▪ USB host for scanner or external PC keyboard</li> <li>▪ Internal Bluetooth (dealer option)</li> <li>▪ Internal MFi Bluetooth 5.0 (factory option)</li> <li>▪ Slot-in Wi-Fi 802.11 a/b/g/n/ac with Bluetooth 5.0 combo module (dealer option)*</li> </ul>	

Model	ML241P	ML341P
<b>Power</b>	Internal universal auto switching power supply <ul style="list-style-type: none"> <li>▪ Input: AC 100-240V, 1.5A, 50-60Hz</li> <li>▪ Output: DC 24V, 2.5A, 60W</li> </ul>	
<b>User Interface</b>	<ul style="list-style-type: none"> <li>▪ 2.3" color LCD</li> <li>▪ 1 bi-color (Green/Red) LED</li> <li>▪ 6 buttons (Menu, Pause/Feed, Up, Down, Left, and Right)</li> <li>▪ 1 power switch</li> </ul>	
<b>Sensor</b>	<ul style="list-style-type: none"> <li>▪ Gap transmissive sensor (position adjustable)</li> <li>▪ Black mark reflective sensor (position adjustable)</li> <li>▪ Ribbon end sensor</li> <li>▪ Head open sensor</li> </ul>	
<b>Real Time Clock</b>	Standard	
<b>Built-in Font</b>	<ul style="list-style-type: none"> <li>▪ 8 alpha-numeric bitmap fonts</li> <li>▪ Monotype Imaging® true type font engine with one CG Triumvirate Bold Condensed scalable font</li> </ul>	
<b>Supported Barcode Format</b>	<ul style="list-style-type: none"> <li>▪ 1D bar code Code 39, Code 93, Code128UCC, Code128 subsets A.B.C, Codabar, Interleave 2 of 5, EAN-8, EAN-13, EAN-128, UPC-A, UPC-E, EAN and UPC 2(5) digits add-on, MSI, PLESSEY, POSTNET, RSS-Stacked, GS1 DataBar, Code 11, China Post</li> <li>▪ 2D bar code PDF-417, Micro PDF 417, Maxicode, DataMatrix, QR code, Aztec, TLC 39, RSS</li> </ul>	
<b>Font &amp; Barcode Orientation</b>	0 / 90 / 180 / 270 degree	
<b>Printer Language</b>	TSPL-EZD (also compatible to EPL, ZPL, ZPL II, and DPL)	
<b>Media Type</b>	Continuous / die-cut / black mark / fan-fold / notch (outside wound)	
<b>Media Width</b>	20 mm – 118 mm (0.8" – 4.7")	
<b>Media Thickness</b>	0.06 mm – 0.19 mm (2.36 mil – 7.48 mil)	
<b>Media Core Diameter</b>	25.4 mm – 38.1 mm (1" – 1.5")	
<b>Label Length</b>	5 mm – 25,400 mm (0.2" – 1000")	5 mm – 11,430 mm (0.2" – 450")

Model	ML241P	ML341P
<b>Environment Condition</b>	<ul style="list-style-type: none"> <li>▪ Operation: 0°C to 40°C (32°F to 104°F); 25% to 85% non-condensing</li> <li>▪ Storage: -40°C to 60°C (-40°F to 140°F); 10% to 90% non-condensing</li> </ul>	
<b>Accessories</b>	<ul style="list-style-type: none"> <li>▪ Quick start guide</li> <li>▪ USB port cable</li> <li>▪ Power cord</li> </ul>	
<b>Factory Option</b>	Internal MFi Bluetooth 5.0	
<b>Dealer Option</b>	<ul style="list-style-type: none"> <li>▪ Peel-off kit (passive)</li> <li>▪ Regular guillotine cutter (full cut)</li> <li>▪ Slot-in 802.11 a/b/g/n/ac Wi-Fi with Bluetooth 5.0 combo module (for device without slot-in housing)</li> <li>▪ Internal Bluetooth 5.0 module*</li> </ul>	
<b>User Option</b>	<ul style="list-style-type: none"> <li>▪ Slot-in 802.11 a/b/g/n/ac Wi-Fi with Bluetooth 5.0 combo module (for device with slot-in housing)</li> <li>▪ KP-200 Plus keyboard display unit</li> <li>▪ Universal cutter tray</li> </ul>	

\*Either wireless or Bluetooth interface is available.



## 2 Unpacking and Inspecting

The printer has been specially packaged to withstand damage during shipment. Retaining the packaging materials is recommended in case you need to ship the printer. When unpacking, ensure that you have received all the following items:

- Barcode printer x1
- Power cord x1
- USB interface cable x1
- User Setup Guide x1

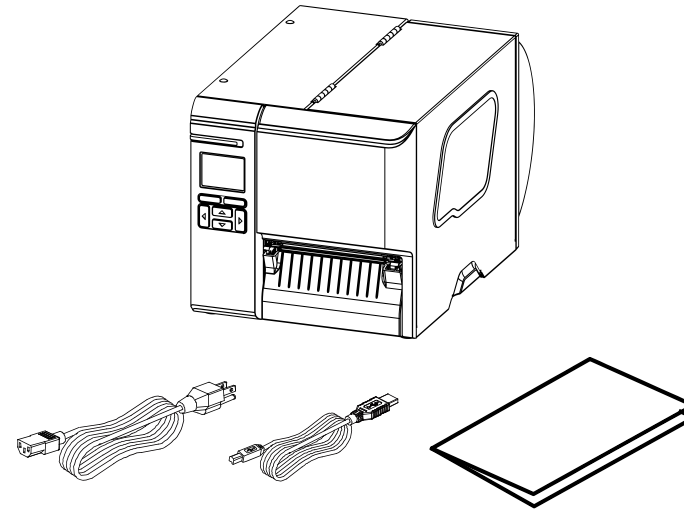

**NOTE:** If anything is missing or damaged, please contact the customer service department of your reseller or distributor.

# 3 Getting to Know Your Printer

## 3.1 Front View



1. LED indicator
2. LCD display
3. Front panel buttons
4. Media window
5. Paper exit chute
6. Media cover handle

### 3.2 Clnner View

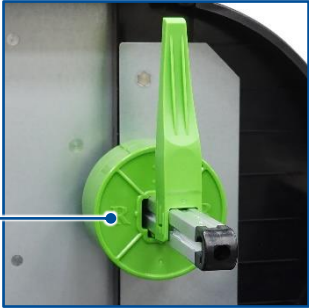
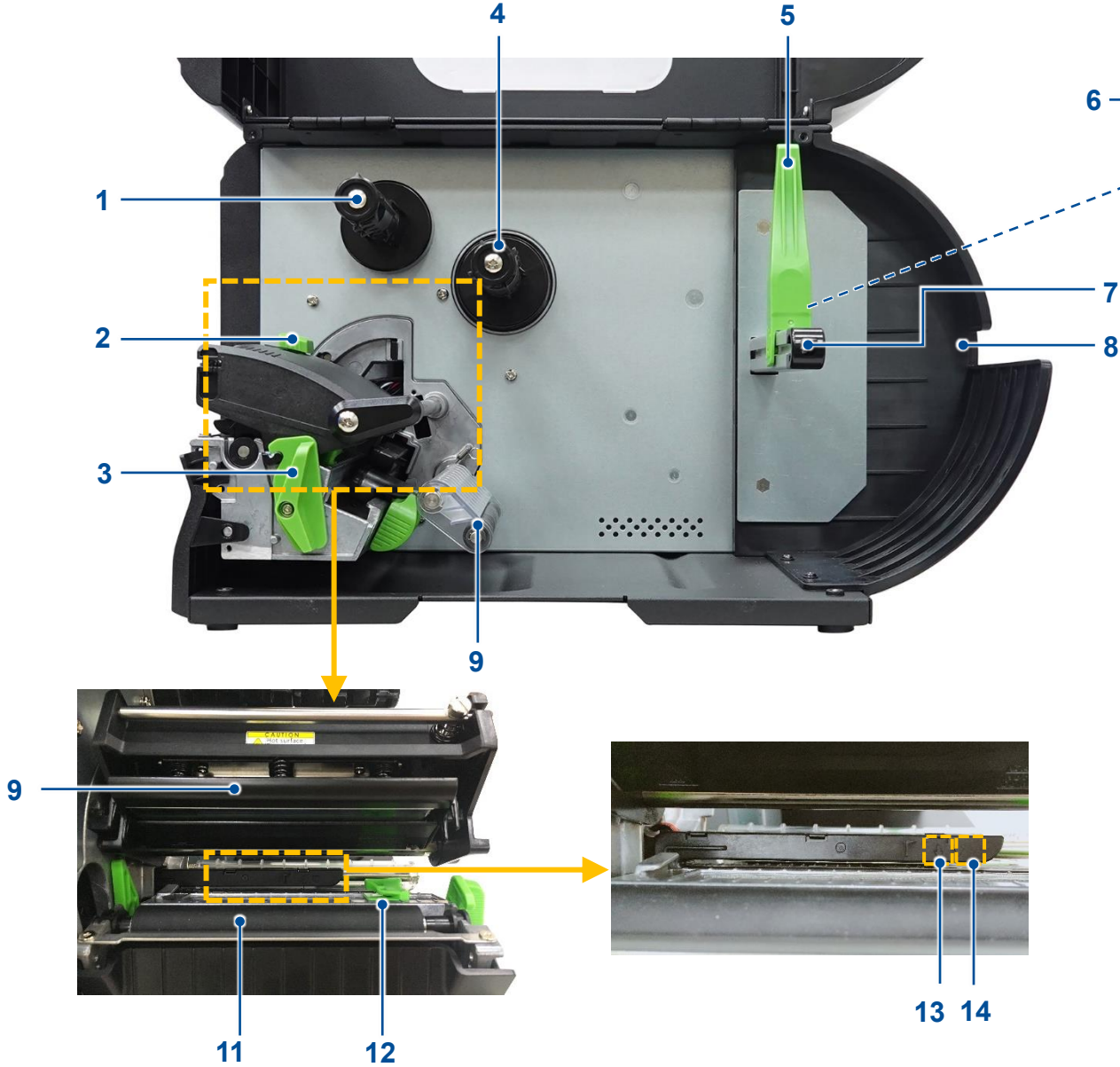

- 1. Ribbon rewind spindle
- 2. Printhead pressure adjustment knob
- 3. Printhead release lever
- 4. Ribbon supply spindle
- 5. Label roll guard
- 6. 3-inch core adapter
- 7. Label supply spindle
- 8. External label entrance chute
- 9. Media damper
- 10. Printhead
- 11. Platen roller
- 12. Label guide
- 13. Black mark sensor (denoted by the ↓ mark)
- 14. Gap sensor (denoted by the ∇ mark)

### 3.3 Rear View



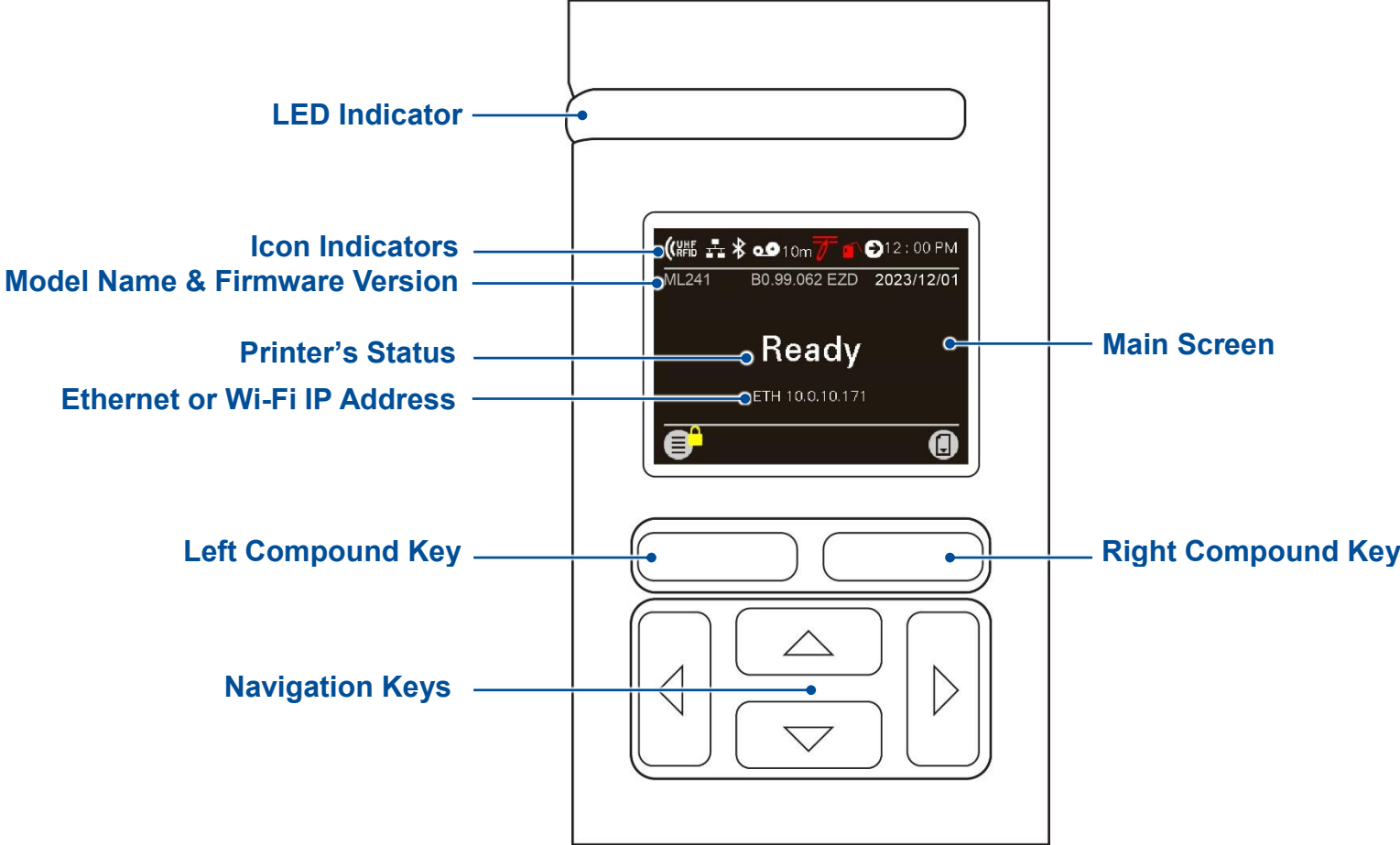

1. External label entrance chute
2. Power switch
3. USB interface (High speed mode)
4. USB host
5. RS-232 interface
6. Slot-in Wi-Fi interface (optional)
7. Ethernet interface
8. Power cord socket

# 4 Operator Interface









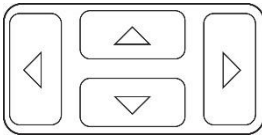



## 4.1 LED Indicator

Color		Description
	Green	<b>ON:</b> The printer is ready for accepting the print job. <b>Blinking:</b> The system is downloading data or the printer is in pause mode.
	Amber	The system is busy.
	Red	<b>ON:</b> The printer's top cover is open or cutter error. <b>Blinking:</b> Other errors, such as paper jam, paper empty, ribbon empty, memory error etc.

## 4.2 Keypads

Keypad Form	Keypad Name	Function
	Left & Right Compound Keys	The function for the Left and Right compound key may vary based on the icon indicators that appear on the LCD control panel.
	Navigation Keys (Left, Up, Down, Right)	Navigates the configurable items in the menu.

## 4.3 Icon Indicators

Icon	Description
	Indicates that the printer features RFID function. <b>NOTE:</b> ML241P series printers do not feature RFID function.
	Indicates that the printer is connected to the wireless network.
	Indicates that the printer is connected to the Ethernet network.
	Indicates that the printer is paired with an external device via Bluetooth or the printer is receiving data via Bluetooth.
	Indicates the remaining amount of the ribbon roll.
	Indicates that the printhead needs maintenance.
	Locks the LCD control panel. As a result, operators cannot change the configuration without admission.
	Opens the menu for more configurable items.
	Confirms your selection.
	Advances one label.

## 4.4 Power-on Utilities



ML241P features a set of utilities which provides quick access to the printer's mostly used functions. Follow the procedures below to launch the power-on utilities and select the function you want to use.

1. Turn off the printer.
2. Press and hold the right compound key and then turn on the printer. Keep holding the right compound key. The display will start playing a series of images in the following sequence that indicates which function is going to be activated. For where the right compound key is located, you may refer to [Keypads](#).
3. When the image that indicates the function you need appears on the display, release the right compound key. The Power-on Utilities will run the function you select.

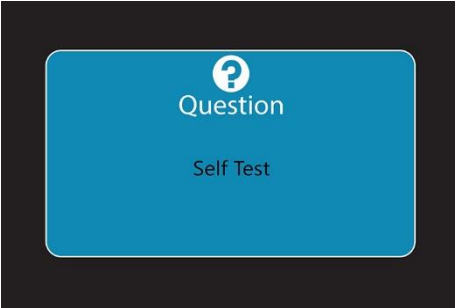
The table below describes the sequence of the images and their corresponding functions.

Sequence & Function		Image
1	<b>Sensor Calibration</b> (Gap / Black Mark Sensor)	 A blue rounded rectangle with a white question mark icon at the top, the word "Question" below it, and "Sensor Calibration" at the bottom. The rectangle is centered on a black background.
2	<b>Self Test</b> (Enters Dump Mode)	 A blue rounded rectangle with a white question mark icon at the top, the word "Question" below it, and "Self Test" at the bottom. The rectangle is centered on a black background.

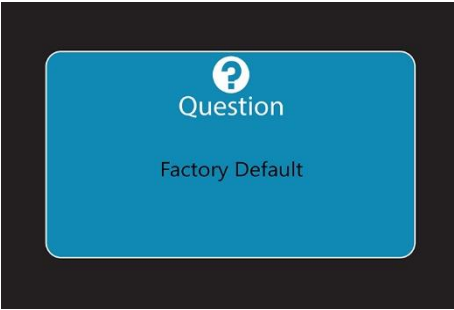

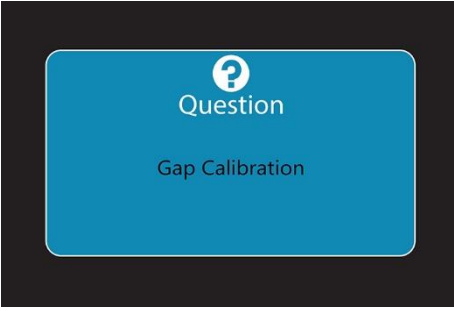
Sequence & Function		Image
3	<b>Factory Default</b>	 <p>A screenshot of a blue dialog box with rounded corners, centered on a black background. At the top is a white question mark icon in a circle, followed by the word 'Question' in white. Below that, the text 'Factory Default' is displayed in white.</p>
4	<b>Black Mark Calibration</b>	 <p>A screenshot of a blue dialog box with rounded corners, centered on a black background. At the top is a white question mark icon in a circle, followed by the word 'Question' in white. Below that, the text 'Bline Calibration' is displayed in white.</p>
5	<b>Gap Calibration</b>	 <p>A screenshot of a blue dialog box with rounded corners, centered on a black background. At the top is a white question mark icon in a circle, followed by the word 'Question' in white. Below that, the text 'Gap Calibration' is displayed in white.</p>
6	<b>Ready</b> (Skips AUTO.BAS)	Main screen will appear on the display if users do not select any of the abovementioned functions.

## 4.5 Web User Interface

Follow the steps below to open the web user interface for the printer:

1. Connect your printer to the Ethernet and obtain the IP address

**NOTE:** For how to know the printer's IP address, you may refer to [TSC Console](#) for detailed information or contact your IT department for further assistance.

2. Open your web browser.
3. Enter the printer's IP address inside the browser's address bar and then press "Enter".

**NOTE:**

- ◆ Due to regional regulations, when logging in for the first time in specific areas, users will be prompted to set a user name and user password.
  1. Set a user name and its password in the **User Name** and **User Password** field.
  2. Set an administrator name and its password in the **Administrator Name** and **Administrator Password** field.
  3. Enter "admin" in the **Enter the current administrator password** field.
  4. Press **Set** to confirm your settings.
- ◆ Users can only view the configurations while administrators will be allowed change the printer settings.

**TSC**

### Welcome to first time use

User Name 1

User Password

Administrator Name 2

Administrator Password

(Password length must be 8 to 15 characters, including one uppercase and lowercase letter and one number)

Enter the current administrator password 3

4

- ◆ The password setting rules are as follows: the length is limited to 8 to 15 characters, it must contain at least one uppercase and lowercase letter and a number. The content can be English letters, numbers, or symbols, but does not support double-byte characters.
- ◆ To consider security, the printer will restart if you enter an incorrect password 5 times.

4. When the screen appears, you can start using the web user interface to manage the printer.

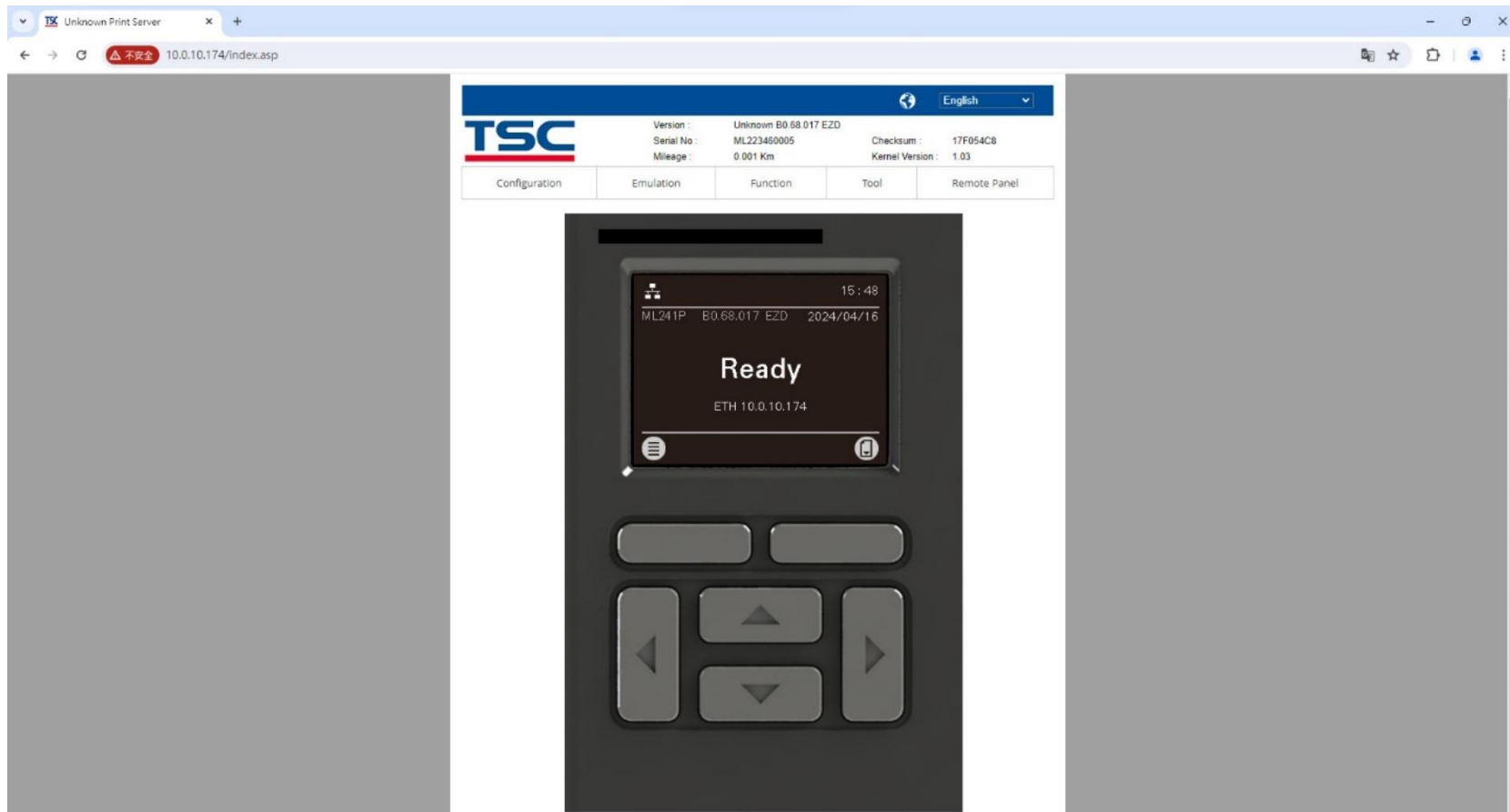

# 4.5.1 Introduction to Web User Interface

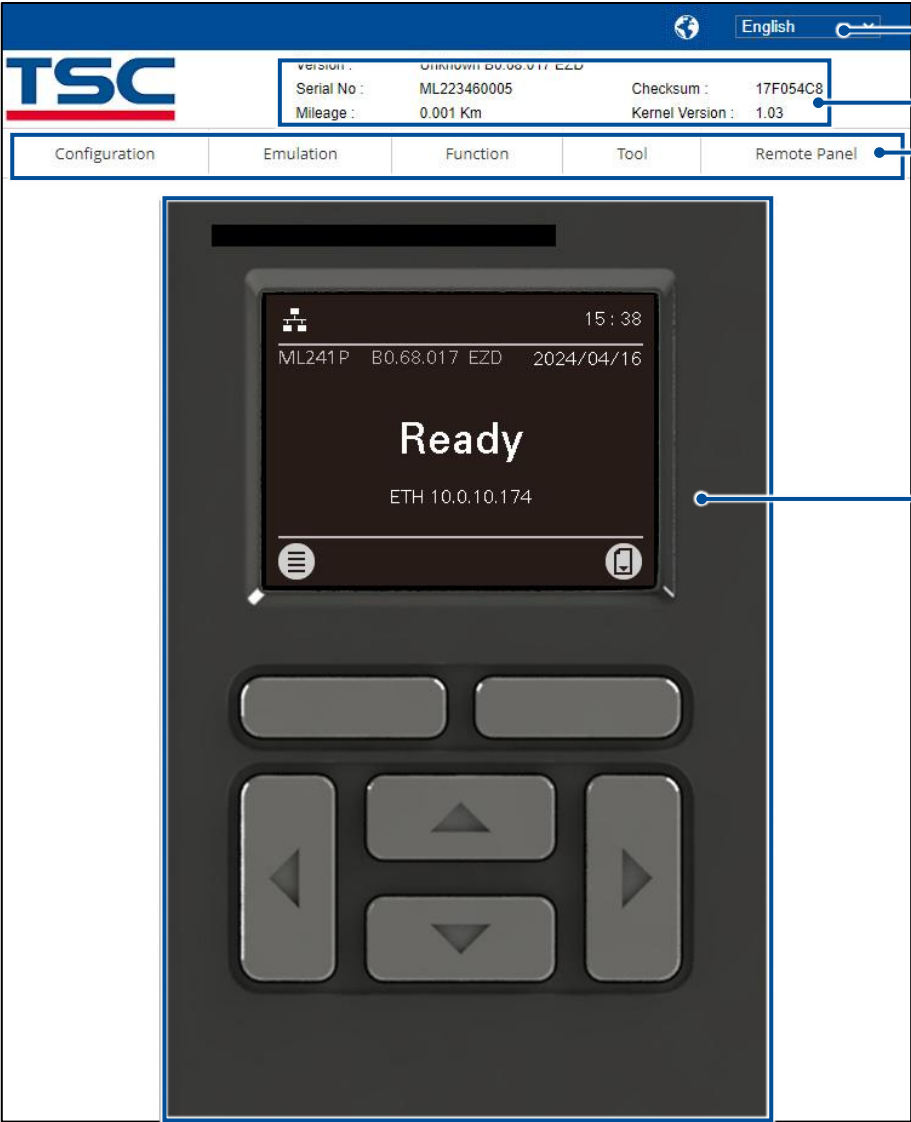

Language switch

Printer's basic information

Function menu bar

Please refer to [Function Menu Bar](#) for more information.

Visualized control interface

The visualized control panel demonstrates the same user interface displayed on the LCD panel. For how to use the buttons and setting options on the control panel, you can refer to [Operator Interface](#).

## 4.5.2 Function Menu Bar

### Configuration

Item		Description
Print	Common	Configures the printer using the TSPL command set. Refer to <a href="#">TSPL</a> for more information.
	Adjust	Adjusts the print and stop location. Refer to <a href="#">TSPL</a> for more information.
	Media	Configures the parameters that relate to the media type and sets the media sensor.
	Calibration	Configures the parameters that affect the media calibration.
RS232		Configures the settings for RS-232.
Bluetooth		Configures the settings for Bluetooth.
Ethernet		Configures the settings for Ethernet.
802.1X		Sets the 802.1X authentication.
Wi-Fi		Configures the settings for Wi-Fi.
Raw Port Filter		Configures the settings for RAW port filter.
RTC Setup		Sets the date and time for the printer.

### Emulation

Item	Description
Z	Emulates Zebra printer language and allows users to configure the printer.
D	Emulates Datamax printer language and allows users to configure the printer.

## Function

Item	Description
<b>SOTI settings</b>	Sets the MQTT server and manages the CA certificate files.
<b>TPH Care</b>	Monitors the printhead's health status.
<b>Email</b>	Sets the SMTP server.
<b>SNTP</b>	Sets the SNTP server.
<b>SNMP</b>	Configures the SNMP (Simple Network Management Protocol) for the printer.
<b>Web Password</b>	Sets the user/administrator name and its corresponding password.
<b>Log</b>	Records the printer's activities.
<b>Function</b>	Provides quick access to the following functions: <ul style="list-style-type: none"><li>• <b>Reset Printer</b></li><li>• <b>Configuration Page</b></li><li>• <b>Sensor Calibration</b></li><li>• <b>Send File to Printer</b></li><li>• <b>Factory Default</b></li><li>• <b>Ignore AUTO.BAS</b></li><li>• <b>Preferred Wi-Fi / Preferred Ethernet</b></li><li>• <b>Select File</b></li></ul>

## Tool

Item	Description
<b>File Manager</b>	Manages the files saved in the built-in memory.
<b>Communication Tool</b>	Sends command sets or instructions to the printer.
<b>Update Firmware</b>	Updates the printer's firmware.
<b>Clear Browsing Record</b>	Clears the browsing record.
<b>Classic Webpage</b>	Switches to the classic user interface.

## Remote Panel

It allows users to open the visualized control panel.

# 5 Setting up the Printer

## 5.1 Connecting the Power Cable

1. Place the printer on a flat surface.
2. Make sure the printer is power off.
3. Connect the printer to the computer with the provided USB cable.
4. Connect the power cord to the power cord socket on the rear side of the printer.  
**IMPORTANT:** Make sure the power switch on the rear side of the printer is set to OFF before connecting the power cord to the printer.
5. Insert the power cord plug into the power outlet socket.



## 5.2 Loading the Ribbon

1. Open the media cover.



2. Install the ribbon onto the ribbon supply spindle and install the paper core onto the ribbon rewind spindle.

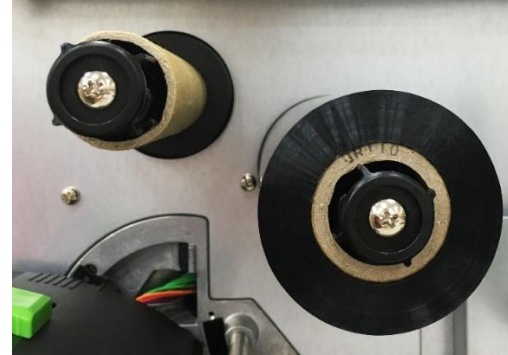

3. Release the lever to open the printhead.



4. Thread the ribbon under the ribbon guide bar and then through ribbon sensor slot.

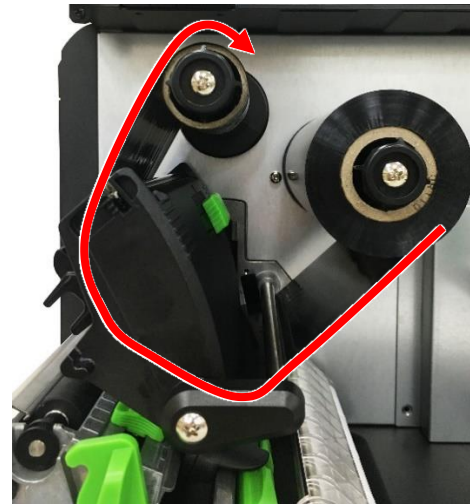

5. Wind the ribbon rewind spindle clockwise ensuring that the ribbon is smoothly stretched and wrinkle-free.

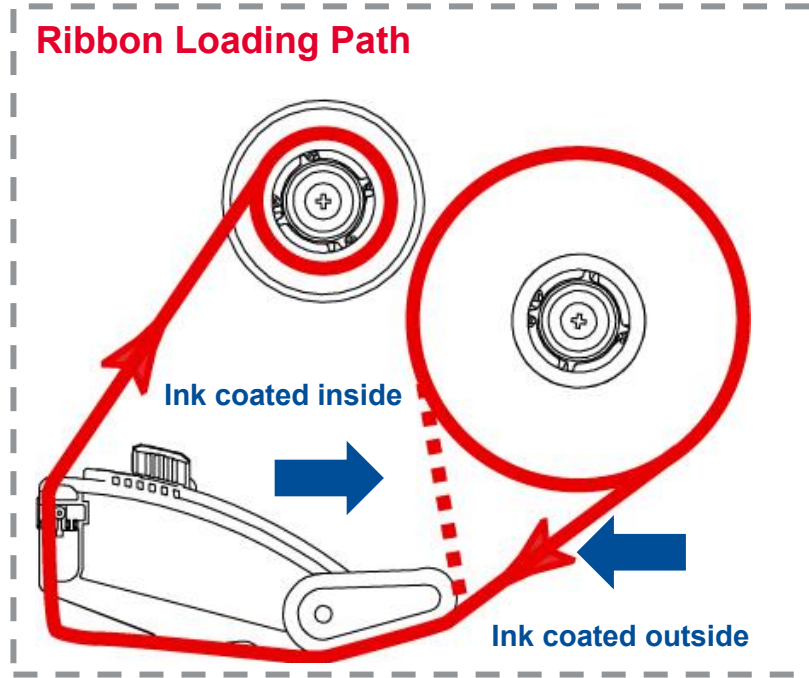
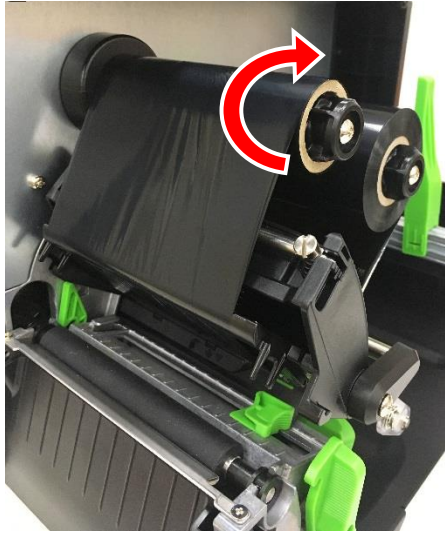

6. Close the printhead.

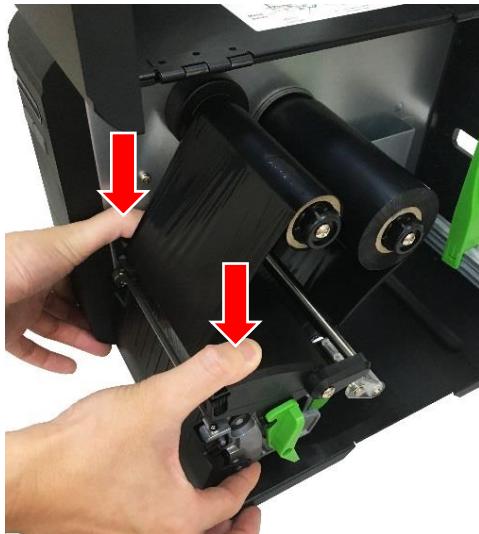

## 5.3 Loading the Media

1. Open the media cover.



2. Slide the media roll guard to the end of the label spindle and then flip down the guard as indicated.



3. Load the media roll and flip up the media roll guard to secure the media roll in place.

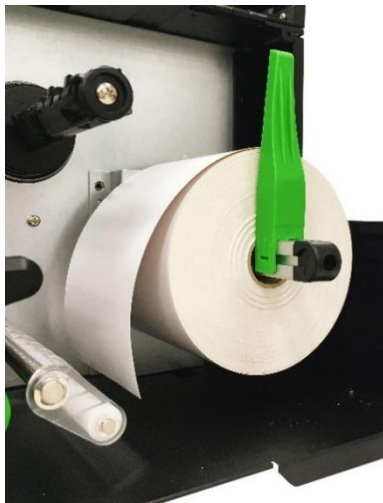

4. Rotate the lever as indicated to release the printhead and then thread the media underneath the damper, through the media sensor, and label guide.



5. Adjust the media sensor location ensuring that the sensor can detect the media.

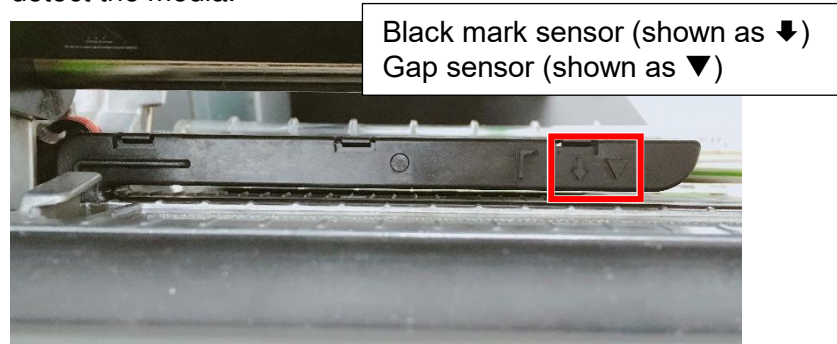

6. Adjust the label guide to secure the media path.

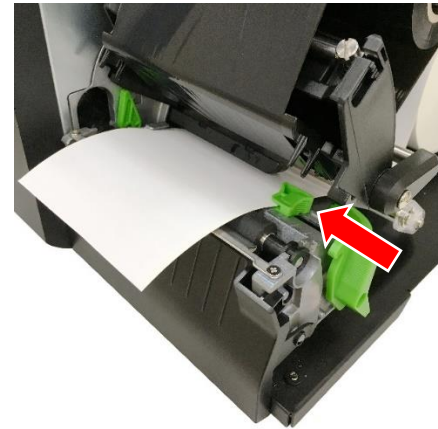

7. Press down to close the printhead mechanism ensuring that the printhead mechanism is correctly secured in place.

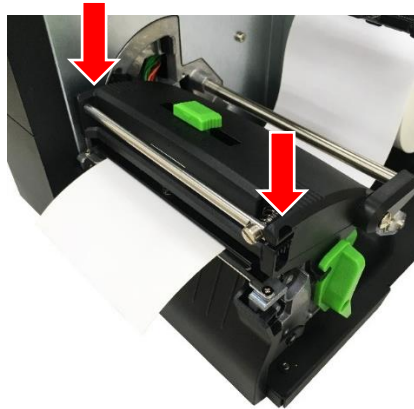

8. *[This step is only applicable to labels with width between 1 and 2 inches]* Slide the printhead pressure adjustment knob to the left side.



9. Perform a calibration for the media in use.

## 5.4 Loading the Fanfold Media

1. Open the media cover.



2. Feed the fanfold media through the external label entrance chute on the rear side of the printer.



3. Feed and thread the media. For how to feed and thread the media, please refer to the [Loading the Media](#).

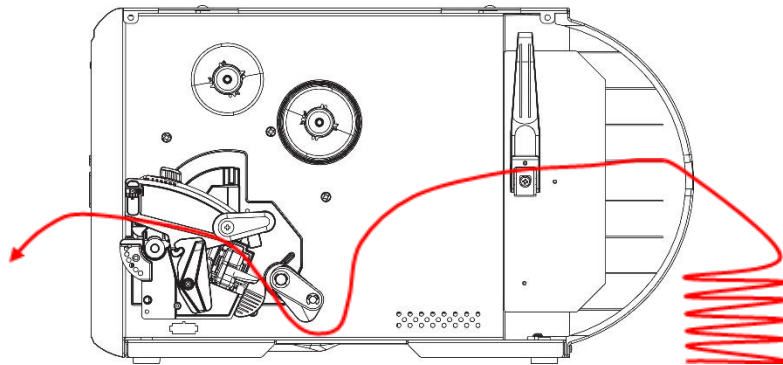

4. Perform a calibration for the media in use.



## 5.5 Loading the Media in Peel-off Mode (Optional)

1. Open the media cover.



2. Load the ribbon and media roll. For how to load the ribbon and media roll, please refer to [Loading the Ribbon](#) and [Loading the Media](#).

3. Perform a calibration for the media in use.

4. Set the printer to the peel-off mode.

5. Open the printhead and peel-off module. Pull out the media (approximately 650 mm long) and then remove some pieces of labels from the liner.

6. Thread the leading edge of the liner through the slot on the peel-off module as indicated.

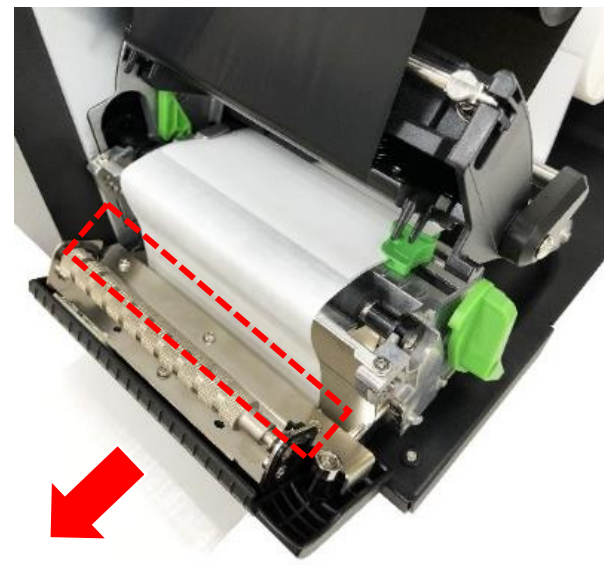
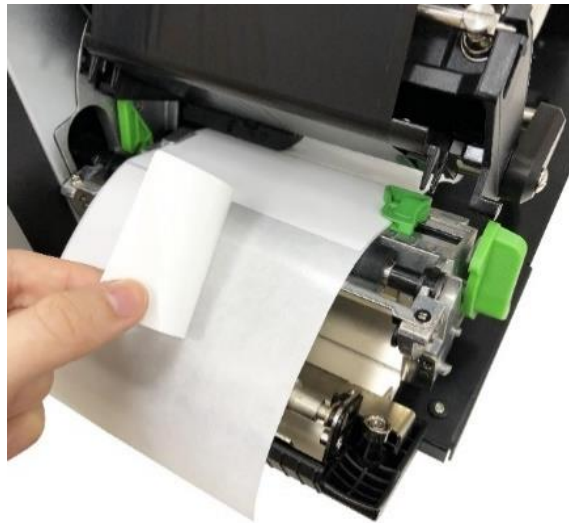

7. Close the printhead, peel-off module, and media cover.



8. When the main screen appears on the display, press the right compound key to force the printer to feed one blank label and check if the printer can correctly peel off the label.

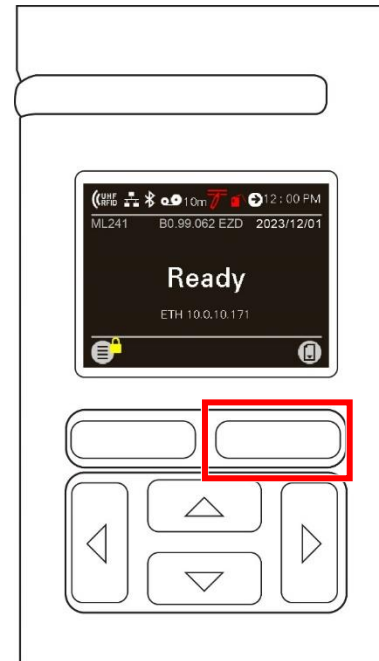

## 5.6 Loading the Media in Cutter Mode (Optional)

1. Open the media cover.



2. Load the ribbon and media roll. For how to load the ribbon and media roll, please refer to [Loading the Ribbon](#) and [Loading the Media](#).

3. Perform a calibration for the media in use.

4. Set the printer to the cutter mode.

5. Open the printhead and cutter module. Thread the media through the slot on the cutter module.

6. Close the printhead, cutter module, and media cover.

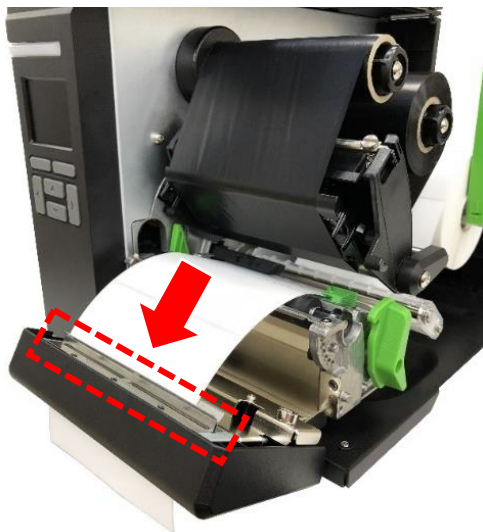



- When the main screen appears on the display, press the right compound key to force the printer to feed one blank label and check if the printer can correctly cut off the label.

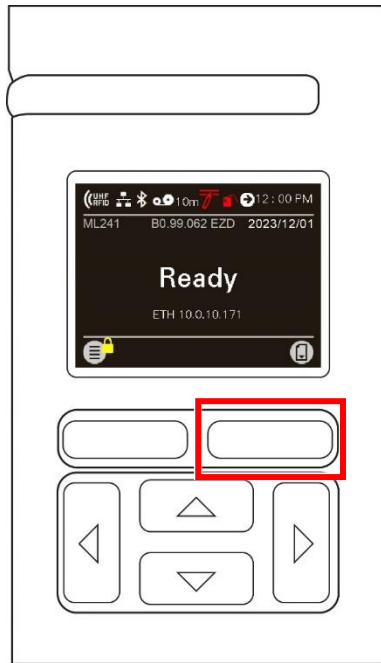

# 6 Adjustment Knobs

## 6.1 Printhead Pressure Adjustment Knob

The printhead pressure adjustment knob features nine positions from left to right. Due to printer's paper alignment is on left side of the mechanism, different media width requires the different pressure. Users can try which level can meet their expectation.



## 6.2 Ribbon Tension Adjustment Knob

The ribbon tension adjustment knob features five positions. The knob enables users to adjust the ribbon tension based on the ribbon width in order to smoothly stretch the ribbon and optimize the print quality.



## 6.3 Mechanism Fine Adjustment to Avoid Ribbon Wrinkles

Ribbon wrinkle is related to the media width, thickness, printhead pressure balance, ribbon film characteristics, print darkness setting etc. If there is wrinkle on the ribbon, you may follow the instructions below to adjust the printer parts.

**Wrinkle happens from label lower right to upper left direction**



1. Switch the ribbon tension adjustment knob clockwise per 1 level and print the label again to check if the wrinkle is gone.
2. If the tension adjustment knob has positioned on the level of innermost side but does not improve the ribbon wrinkle, please switch the printhead pressure adjustment knob per level and print the label again to check if the wrinkle is gone.
3. If the wrinkle can't be avoided, please contact the Customer Service Department of your purchased reseller or distributor for service.

## Wrinkles happens from label lower left to upper right direction



1. Switch the ribbon tension adjustment knob counterclockwise per 1 level and print the label again to check if the wrinkle is gone.
2. If the tension adjustment knob has positioned on the level of outermost side but does not improve the ribbon wrinkle, please switch the printhead pressure adjustment knob per level and print the label again to check if the wrinkle is gone.
3. If the wrinkle can't be avoided, please contact the Customer Service Department of your purchased reseller or distributor for service.

# 7 TSC Console

TSC Console is a management tool combining the Printer Management, Diagnostic Tool, CommTool and Printer Webpage settings, which enables you to adjust printer's settings/status; change printers' settings; download graphics, deploy fonts, graphics, label templates or upgrade the firmware to the group of printers, and send additional commands to printers at the same time.

## 7.1 Starting TSC Console

1. Double click TSC Console icon to start the software.

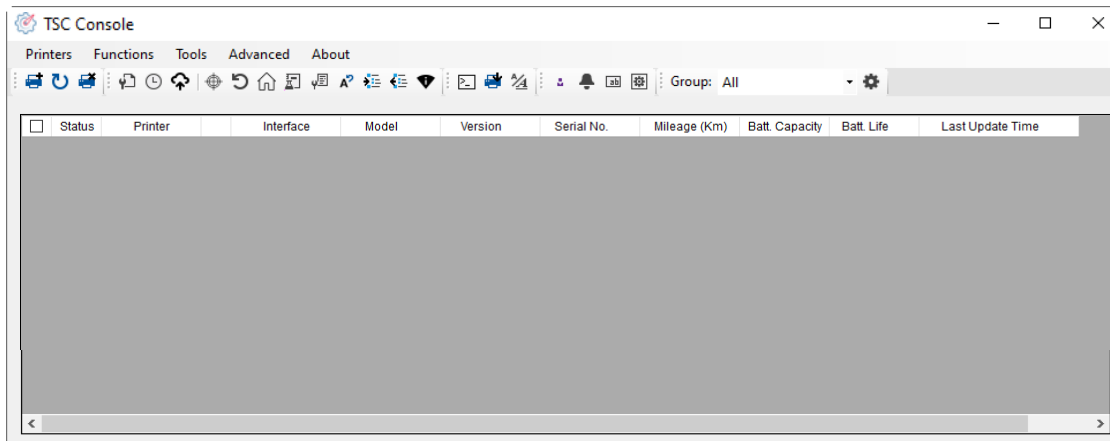

2. Manually add the devices by clicking **Printer > Add Printers**.

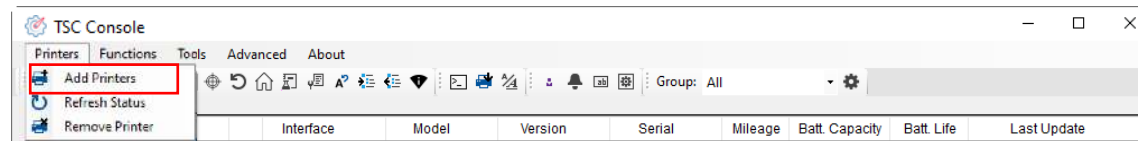

3. Select the current interface of the printer.

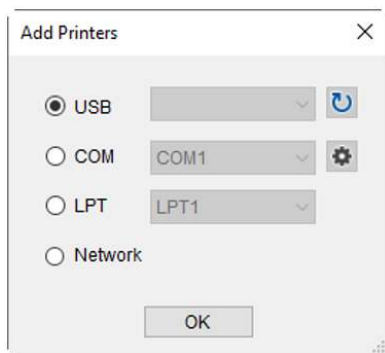

4. The printer will be added to **TSC Console's** interface.

5. Select the printer and set the settings.

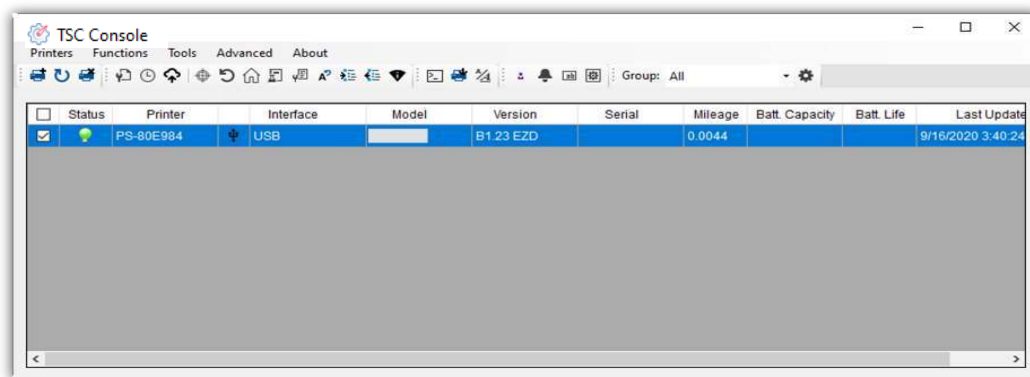

**NOTE:** For more information, you may refer to TSC Console User Manual.

## 7.2 Adding the Ethernet Interface

1. Use **USB** or **COM** to establish the interface on **TSC Console**.

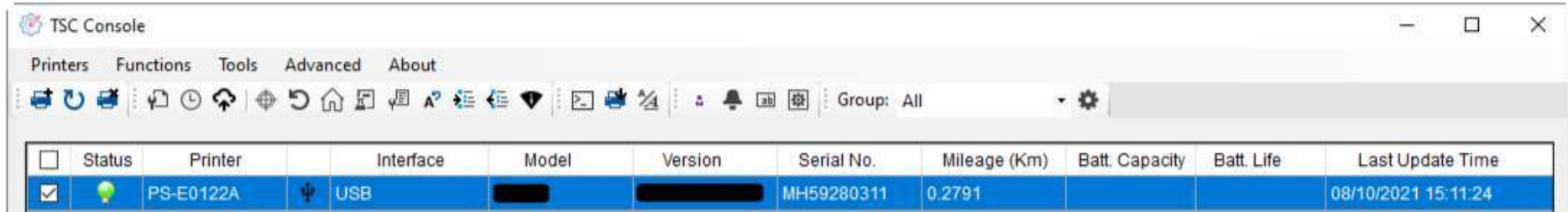

The screenshot shows the TSC Console application window. At the top, there are menu items: Printers, Functions, Tools, Advanced, and About. Below the menu is a toolbar with various icons. A status bar at the bottom of the toolbar shows 'Group: All' and a gear icon. The main area contains a table with the following columns: Status, Printer, Interface, Model, Version, Serial No., Mileage (Km), Batt. Capacity, Batt. Life, and Last Update Time. The table has one row of data:

Status	Printer	Interface	Model	Version	Serial No.	Mileage (Km)	Batt. Capacity	Batt. Life	Last Update Time
<input checked="" type="checkbox"/>	PS-E0122A	USB			MH59280311	0.2791			08/10/2021 15:11:24

2. Double click to enter the **Printer Configuration Page** > Click **Ethernet** tab > Check the **IP Address**.

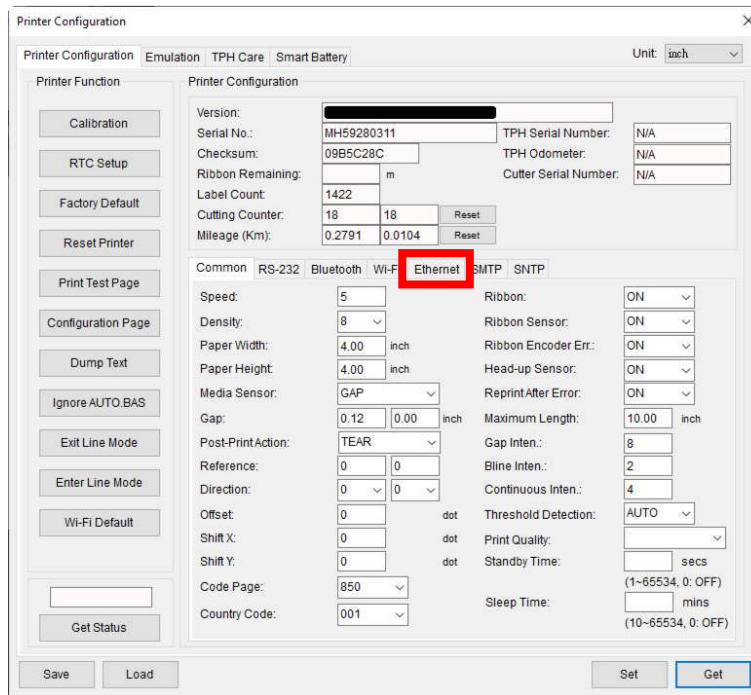

The screenshot shows the Printer Configuration dialog box. The 'Ethernet' tab is selected and highlighted with a red box. The dialog box has several sections: Printer Function, Printer Configuration, and a tabbed interface for network settings. The Ethernet tab is currently active, showing options for DHCP and Static IP, along with fields for IP Address, Subnet Mask, Gateway, and MAC Address. A red arrow points from this dialog box to the next screenshot.

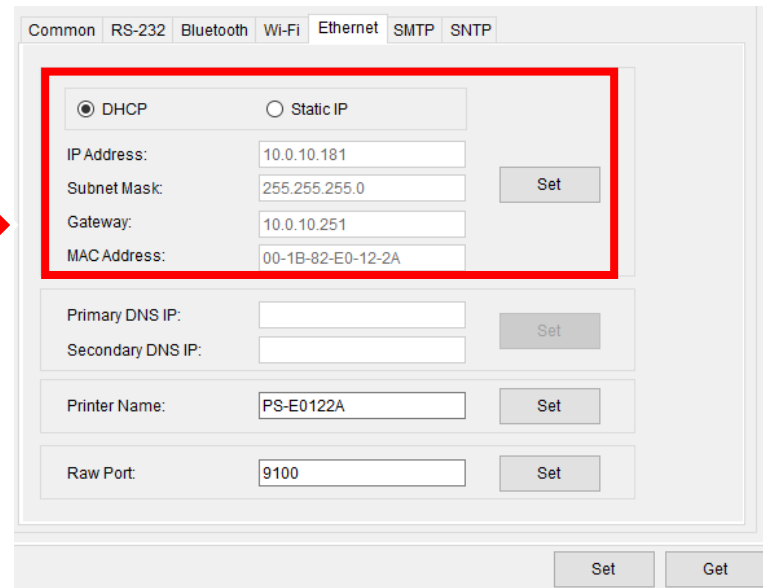

This is a close-up view of the Ethernet configuration section. It shows two radio buttons:  DHCP and  Static IP. Below them are four input fields: IP Address (10.0.10.181), Subnet Mask (255.255.255.0), Gateway (10.0.10.251), and MAC Address (00-1B-82-E0-12-2A). Each field has a 'Set' button to its right. Below these fields are sections for Primary DNS IP, Secondary DNS IP, Printer Name (PS-E0122A), and Raw Port (9100), each with a 'Set' button. At the bottom of the dialog, there are 'Set' and 'Get' buttons.



3. Return to **TSC Console** main page > Click **Add Printer** on the top left of the window.

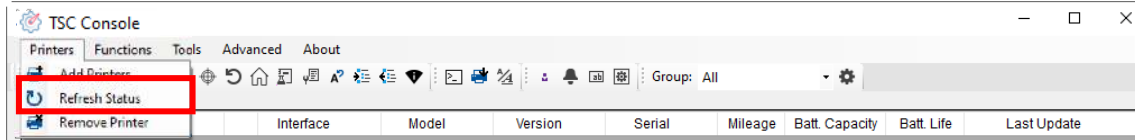

4. Choose **Network** > Key in the **IP Address** > Click **Discover** to establish the Ethernet interface.

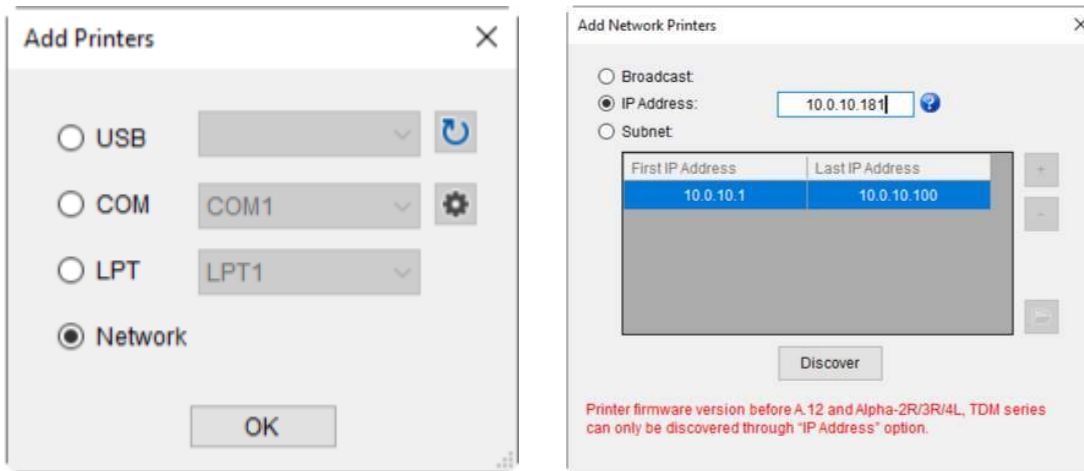

5. The notification will pop up > Click **OK** to close the window > The Ethernet interface will be shown on **TSC Console**.

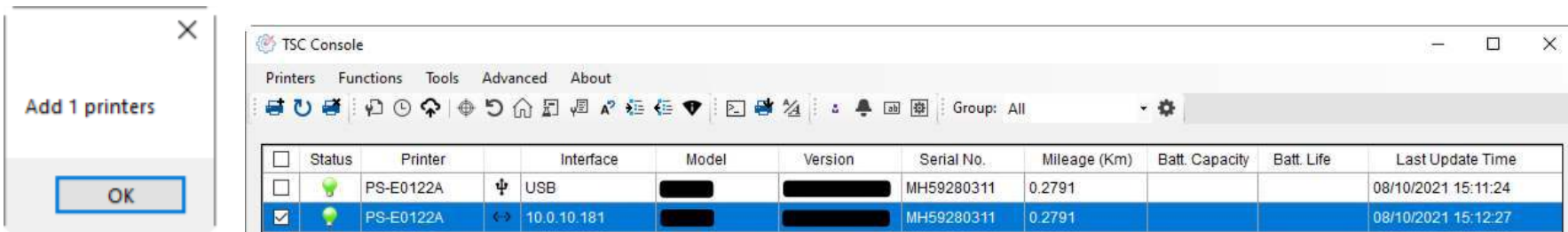

# 7.3 Set Wi-Fi and Add to TSC Console Interface

- 1. Use **USB** or **COM Port** to set up the interface.
- 2. Double click to enter the printer configuration page.

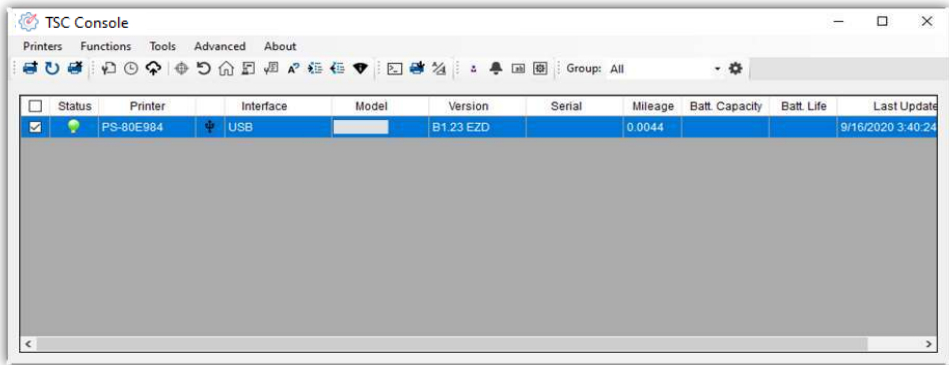

- 3. Click **Get** to receive printer's information.
- 4. Click **Wi-Fi** to the wi-fi setting page.

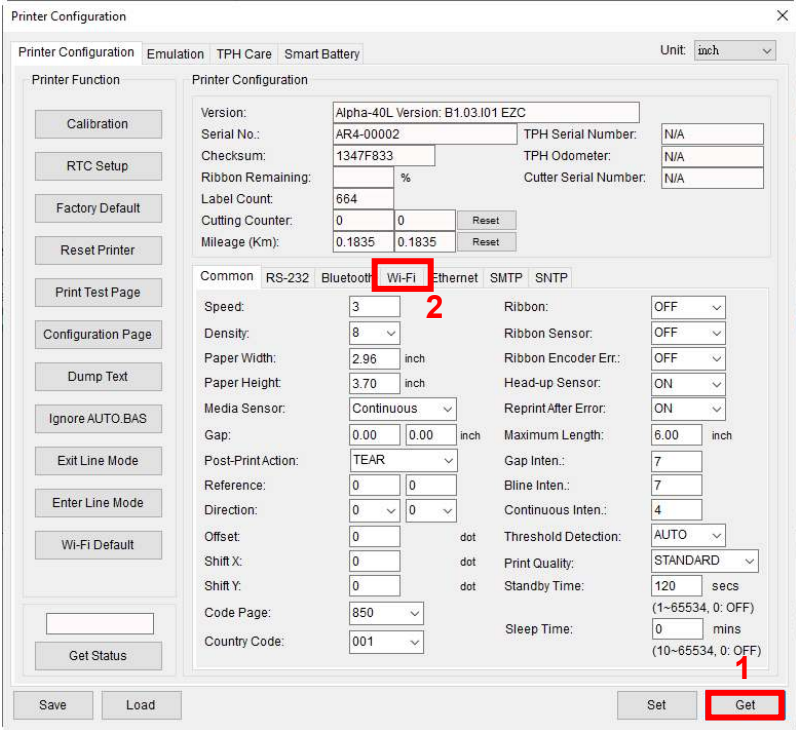

### For WPA-Personal

- (1) Fill-in the **SSID**.
- (2) Select the Encryption option to **WPA-Personal**.
- (3) Fill-in the Key.
- (4) Select **DHCP** to **ON**. (For **OFF** option, please fill-in the IP Address, Subnet Mask and Gateway)
- (5) After setting, click the **Set** button.

**NOTE:** Before setting, the entered field will be shown in yellow for reminding. On DHCP, user can change the printer name by another model name in “Printer Name” field. User also can change the raw port in “Raw Port” field.

The screenshot shows the 'Wi-Fi' configuration page. The 'Built-in Wi-Fi Module' section is active. The 'SSID' field is highlighted in yellow and contains 'SSID\_1'. The 'WLAN Encryption' dropdown is set to 'WPA-Personal'. The 'Key' field is highlighted in yellow and contains '\*\*\*\*\*'. The 'DHCP' dropdown is set to 'ON'. The 'Subnet Mask' field contains '0.0.0.0' with a red '1' next to it. The 'Set' button at the bottom right is highlighted with a red box and a red '2' next to it.

### For WPA-Enterprise

- (1) Fill-in the **SSID**.
- (2) Select the Encryption option to **WPA2-Enterprise**.
- (3) Select DHCP to **ON** (For **OFF** option, please fill-in the IP Address, Subnet Mask and Gateway)
- (4) Select the **EAP Type** option. (For **EAP-TLS** option, please upload the CA and Key for mutual authentication, integrity-protected cipher suite negotiation, and key exchange between two endpoints.)
- (5) After setting, click the **Set** button.

**NOTE:** Before setting, the entered field will be shown in yellow for reminding. On DHCP, user can change the printer name by another model name in “Printer Name” field. User also can change the raw port in “Raw Port” field.

The screenshot shows the 'Wi-Fi' configuration page. The 'Built-in Wi-Fi Module' section is active. The 'SSID' field is highlighted in yellow and contains 'SSID\_2'. The 'WLAN Encryption' dropdown is set to 'WPA-Enterprise'. The 'Key' field is highlighted in yellow and contains '\*\*\*\*\*'. The 'DHCP' dropdown is set to 'ON'. The 'Subnet Mask' field contains '0.0.0.0' with a red '1' next to it. The 'EAP Type' dropdown is highlighted with a red box and a red '2' next to it. The 'Set' button at the bottom right is highlighted with a red box and a red '3' next to it.

5. After clicking **Set** button, it'll pop-up the window tip as below shown.

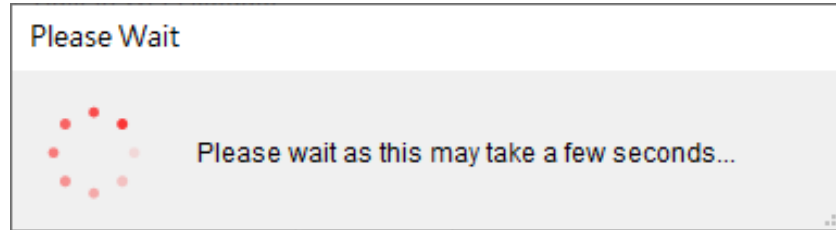

6. IP address will be shown in the "IP address" field and the Wi-Fi logo and IP address will be displayed on the LCD control panel.

**NOTE:** IP address should be shown within about 5-15 seconds after printer turn on. If not, please refer to steps below to initialize the printer Wi-Fi module settings then to setup it again.

7. Remove the cable between the computer and the printer.
8. Go to main page, click **Add Printer** to add the printer via **Network**.
9. Select the printer and enter the setting page by double clicking the printer.
10. Click the **Print Test Page** button to print the test page via Wi-Fi interface.

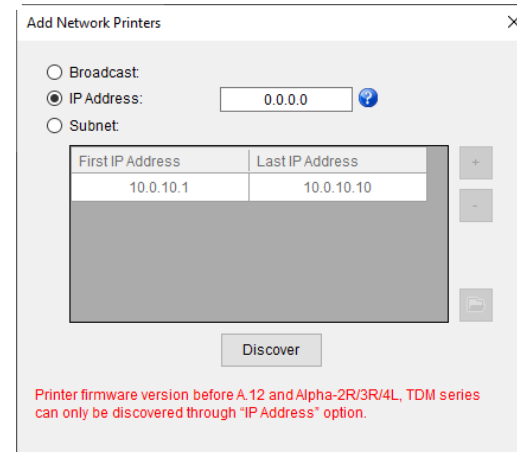

## 7.4 Initialize the Printer Wi-Fi Setting

1. Return to the main page of TSC Console.
2. Click **Functions** to expand the page.

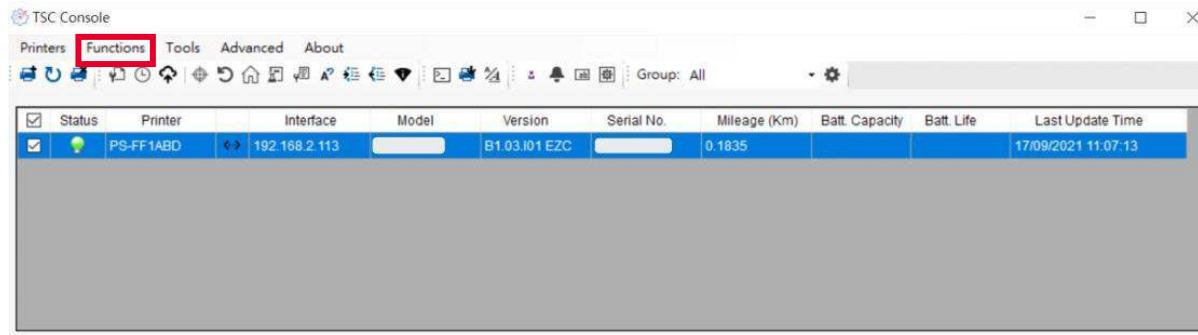

3. Click **Wi-Fi Default** to initialize the printer Wi-Fi module setting to factory default setting.

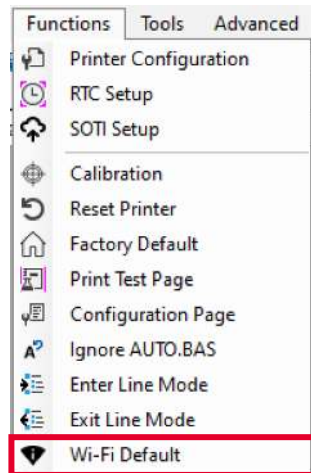

## 7.5 TPH Care

**TPH Care** provides users to check the condition of the printhead and be able to set the dot failure threshold for indicating errors when the threshold is triggered.



This option is used to enable (ON)/ disable (OFF) the TPH care function.

This option is used to check the numbers of unhealthy TPH dot element.

This option is used to detect the unhealthy TPH dot.

This option is used to set the threshold for unhealthy TPH dot number.

This image is used to check the relative position of the unhealthy TPH dot.

This option is used to print a TPH test image to check the TPH printing result.

1. Enable the TPH Care function. (Note: The default is disabled/OFF.) Then click "Get TPH care profile" button and a diagram will show in the area above.
2. If the profile is flat, it means that the printhead is good. Check "Unhealthy TPH dot number". If the result is zero (0), that means the printhead is good.
3. Bad dots are presented as a spike in the profile. The arrow in below profile indicates the presence of potentially damaged dots and printer will stop printing.



## 7.6 Printer Function

Printer Function could be found in Printer Configuration. “Printer Function” will be shown on the left side of the window.

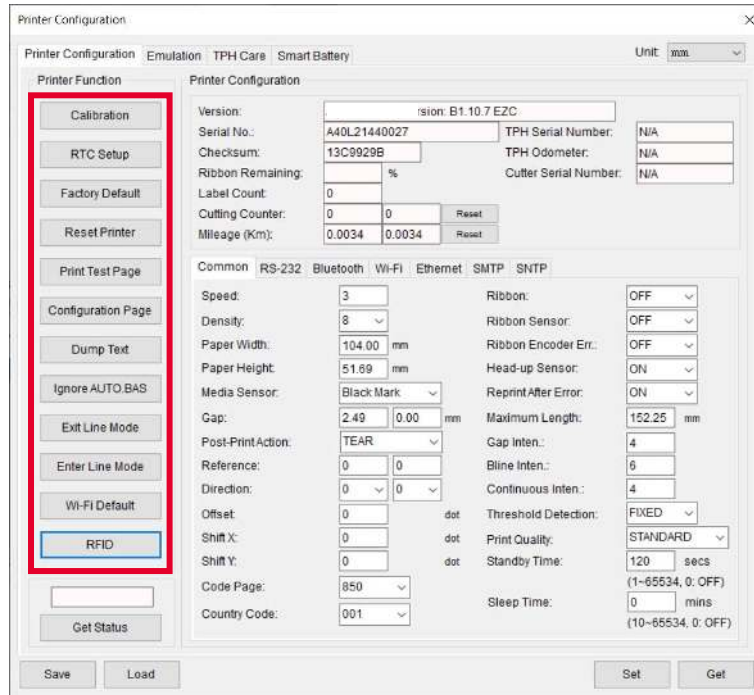

機能	説明
Calibration	Detects media types and the size of the label.
RTC Setup	Synchronizes printer with Real Time Clock on PC.
Factory Default	Initializes the printer to default settings.
Reset Printer	Reboots the printer.
Print Test Page	Prints out test page according to the specified label size and sensor type.
Configuration Page	Prints out printer's configurations.
Dump Text	Activates the printer to dump mode.
Ignore AUTO BAS	Ignores AUTO.BAS file when printer boot up.
Exit Line Mode	Exits the line mode to page mode
Enter Line Mode	Leaves page mode and enter line mode
Wi-Fi Default	Restores the Wi-Fi settings to factory defaults.
RFID	Configures RFID functions. <b>NOTE:</b> ML241P series printers do not feature RFID functions.

## 7.7 Setting Post-Print Action

When the printer is equipped with other option kits, ex: cutter, peeler, rewinder, please select the mode after finishing the calibration.

Follow below procedure to set the post action for the printing:

**Refer Ch 5.1 to Connect the printer with TSC Console > Double click the printer > The Printer Configuration Page will pop up > Click Get to load information > Go to Common Tab > Find Post-Print Action > Select the mode depends on users' application > Click Set.**

Printer Configuration

Printer Configuration Emulation TPH Care Smart Battery Unit: mm

Printer Function

Calibration  
RTC Setup  
Factory Default  
Reset Printer  
Print Test Page  
Configuration Page  
Dump Text  
Ignore AUTO BAS  
Exit Line Mode  
Enter Line Mode  
Wi-Fi Default  
Get Status

Printer Configuration

Version: [Redacted]  
Serial No.: [Redacted] TPH Serial Number: N/A  
Checksum: 1344B9B1 TPH Odometer: N/A  
Ribbon Remaining: [Redacted] % Cutter Serial Number: N/A  
Label Count: 553  
Cutting Counter: 0 0 Reset  
Mileage (Km): 0.0913 0.0913 Reset

Common RS-232 Bluetooth Wi-Fi Ethernet SMTP SNTP







Speed: 3 Ribbon: OFF  
Density: 8 Ribbon Sensor: OFF  
Paper Width: 104.00 mm Ribbon Encoder Err.: OFF  
Paper Height: 74.05 mm Head-up Sensor: ON  
Media Sensor: Black Mark Reprint After Error: ON  
Gap: 1.99 0.00 mm Maximum Length: 152.25 mm  
Post-Print Action: [Redacted] Gap Inten.: 7  
Reference: OFF Bline Inten.: 7  
Direction: TEAR Continuous Inten.: 4  
Offset: PEEL Threshold Detection: AUTO  
Shift X: CUTTER Print Quality: STANDARD  
Shift Y: REWIND Standby Time: 120 secs  
Code Page: 850 Sleep Time: 0 mins  
Country Code: 001 (10-655 OFF)

Save Load Set Get



# 8 Printer Configuration

All setting options for the printer can be divided into 6 sub-menus. It allows users to configure the printer without connecting the printer to a computer.

Icon	Name	Description	Icon	Name	Description
	Setting	Configures the printer using the TSPL or ZPL2 command set.		Advanced	Allows users to set the OSD language, reset the printer to factory default, set the date and time, etc.
	Sensor	Calibrates the media sensor.		File Manager	Manages the files saved in the built-in memory.
	Interface	Sets the communication interfaces.		Diagnostic	Helps users to troubleshoot the problems.

To open the 6 sub-menus:

1. Use the navigation keys to select the  icon.
2. Press the left compound key to open the sub-menus.

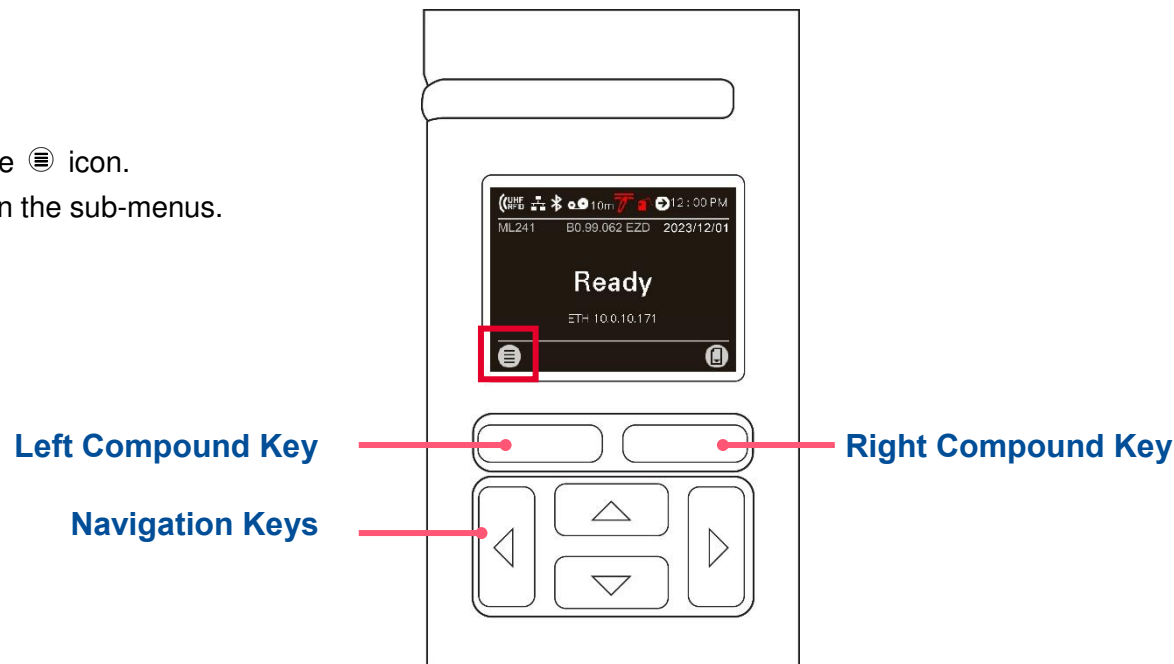

## 8.1 Setting

It allows users to configure the printer using the TSPL or ZPL2 command set.

**NOTE:** TSPL indicates TSC printer language and ZPL2 indicates an emulation of Zebra printer language.

To configure the printer:

1. Press the right compound key to switch between the TSPL and ZPL2 command set.

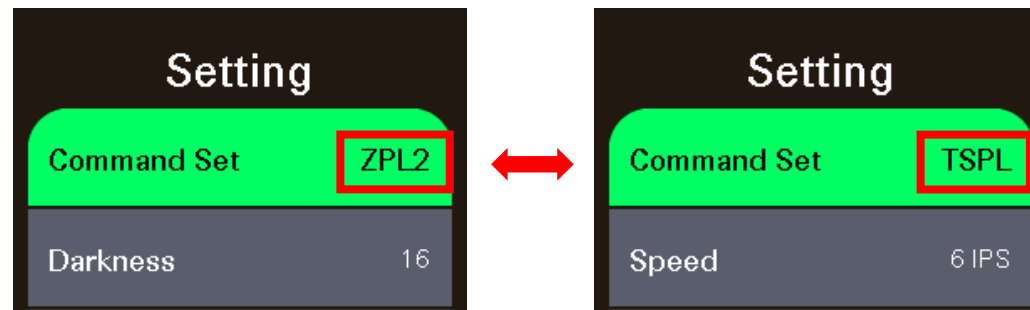

2. Use the navigation to select the item you want to configure.
3. Press the right compound key and start configuring the selected item.

## 8.1.1 TSPL

The following illustration and table describe the TSPL command set.

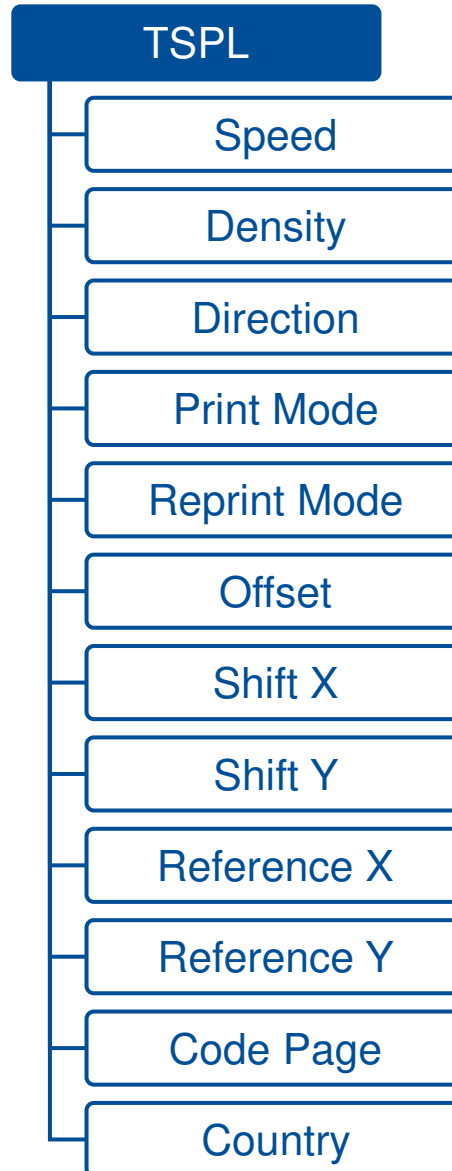

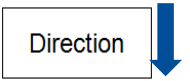
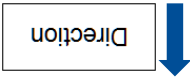
Item	Description	Default
<b>Speed</b>	Sets the print speed.	5 (203 dpi) 4 (300 dpi)
<b>Density</b>	Sets the print darkness. Setting range: 0 to 15.	8
<b>Direction</b>	Sets the printout direction. Setting options: 0 or 1. (Feed direction: ↓)  When set to <b>1</b>   When set to <b>0</b> 	0
<b>Print Mode</b>	Sets the print mode. <ul style="list-style-type: none"> <li>• <b>Batch Mode:</b> When printer finishes the print job, the label will be fed to a location where allows users to tear the label.</li> <li>• <b>Cutter Batch:</b> Sets the printer to cut the label when the print job is finished.</li> <li>• <b>Cutter Mode:</b> Enables the cutter mode.</li> <li>• <b>Peeler Mode:</b> Enables the peel-off mode.</li> <li>• <b>None:</b> TOF (Top of Form, the position the printer starts printing) for the next label is aligned with the printhead's burn line.</li> </ul>	Batch Mode
<b>Reprint Mode</b>	Enables/Disables <b>Reprint Mode</b> . When set to <b>Enable</b> , you can reprint the last label printed by pressing the <b>Reprint</b> button.	Disable
<b>Offset</b>	Specifies the stop position for each operation. Setting range: -203 to 203 dot.	0
<b>Shift X</b>	Specifies the amount to shift an image horizontally for precise print position on the label. Setting range: -203 to 203 dot.	0
<b>Shift Y</b>	Specifies the amount to shift an image vertically for precise print position on the label. Setting range: -203 to 203 dot.	0
<b>Reference X</b>	Specifies the x-coordinate relative to the origin. Setting range: 0 to 999 dot.	0

Item	Description	Default
<b>Reference Y</b>	Specifies the y-coordinate relative to the origin. Setting range: 0 to 999 dot.	0
<b>Code Page</b>	Specifies the code page which is associated with the supported characters.	850
<b>Country</b>	Sets the country code.	001

**ATTENTION:** If you print using a label design software or other label printing tools, the commands from the software or tool will overwrite the printer's settings you set through the LCD display panel.

## 8.1.2 ZPL2

The following illustration and table describe the ZPL2 command set.

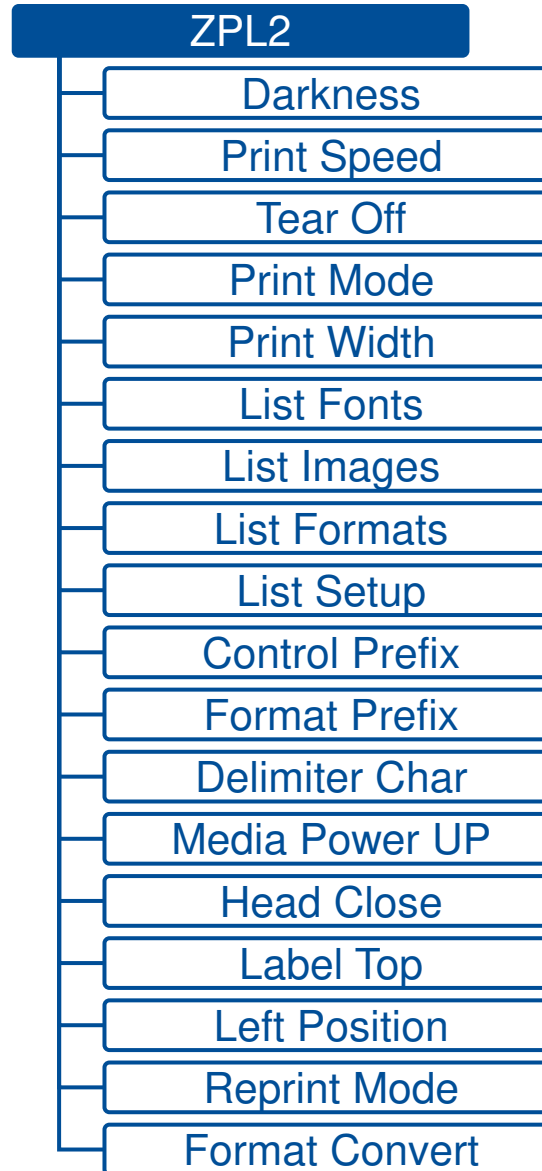

Item	Description	Default
<b>Darkness</b>	Sets the print darkness. Setting range: 0 to 30.	16
<b>Print Speed</b>	Sets the print speed.	5 (203 dpi) 4 (300 dpi)
<b>Tear Off</b>	Specifies the stop position of the media after a label is printed. Setting range: -120 to 120 dots.	0
<b>Print Mode</b>	<p>Sets the print mode.</p> <ul style="list-style-type: none"> <li>• <b>Tear Off:</b> Allows users to tear off a label after it is printed.</li> <li>• <b>Cutter:</b> Enables the cutter mode.</li> <li>• <b>Peel Off:</b> Enables the peel-off mode.</li> </ul>	Tear Off
<b>Print Width</b>	Specifies the print width. Setting range: 2 to 864 dot.	812
<b>List Fonts</b>	Prints the list of all linked fonts saved in the printer's memory.	
<b>List Images</b>	Prints the list of all linked images saved in the printer's memory.	
<b>List Formats</b>	Prints the list of all linked label formats saved in the printer's memory.	
<b>List Setup</b>	Prints the printer's configurations.	
<b>Control Prefix</b>	Sets the control command prefix. Setting range: 0 - FF (~).	7E (~)
<b>Format Prefix</b>	Sets the control format prefix. Setting range: 0 - FF (^).	5E (^)
<b>Delimiter Char</b>	Sets the delimiter character to separate the command parameters. Setting range: 0 - FF (,).	2C (,)
<b>Media Power Up</b>	<p>Configures the printer to take specific action after powering on the printer.</p> <ul style="list-style-type: none"> <li>• <b>No Motion:</b> The printer will take no action. The sensor values and media position will not be changed.</li> <li>• <b>Length:</b> The printer will detect the length of a label and then advance the label to the correct position.</li> <li>• <b>Calibration:</b> The printer will run the calibration and then advance the media to the correct position according to the calibration results.</li> <li>• <b>Feed:</b> The printer will advance the label to the configured position.</li> </ul>	No Motion

Item	Description	Default
<b>Head Close</b>	Configures the printer to take specific action after closing the printhead. <ul style="list-style-type: none"> <li>• <b>No Motion:</b> The printer will take no action. The sensor values and media position will not be changed.</li> <li>• <b>Length:</b> The printer will detect the length of a label and then advance the label to the correct position.</li> <li>• <b>Calibration:</b> The printer will run the calibration and then advance the media to the correct position according to the calibration results.</li> <li>• <b>Feed:</b> The printer will advance the label to the configured position.</li> </ul>	No Motion
<b>Label Top</b>	Specifies the amount to shift an image horizontally for precise print position on the label. Setting range: -120 to 120 dot.	0
<b>Left Position</b>	Specifies the amount to shift an image vertically for precise print position on the label. Setting range: -9999 to 9999.	0
<b>Reprint Mode</b>	When <b>Reprint Mode</b> is enabled, users can press  on the main screen to reprint the last label.	Disable
<b>Format Convert</b>	Selects the bitmap scaling factor. The first number indicates the original dpi (dots per inch) value while the second number indicates the dpi you want to scale. <ul style="list-style-type: none"> <li>• <b>None:</b> No change</li> <li>• <b>300/600</b></li> <li>• <b>200/600</b></li> <li>• <b>150/600</b></li> <li>• <b>150/300</b></li> </ul>	None

**ATTENTION:** If you print using a label design software or other label printing tools, the commands from the software or tool will overwrite the printer's settings you set through the LCD display panel.



## 8.2 Sensor

The setting options in the **Sensor** menu allows users to calibrate the printer based on what kind of the media they want to use. It is recommended to perform a calibration anytime you use a different media.

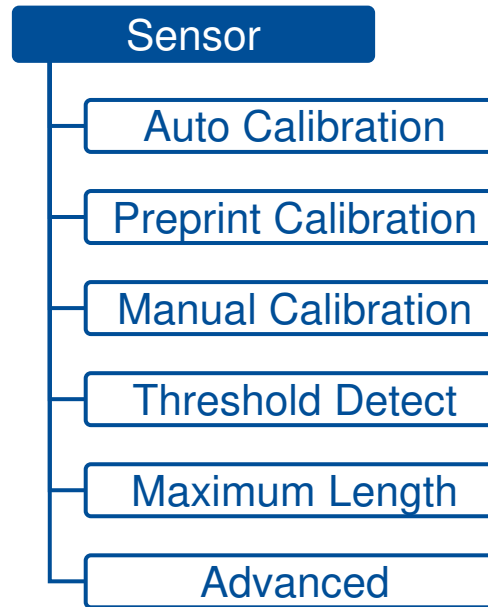

Item	Description	Default
<b>Auto Calibration</b>	Detects the media type and automatically performs the calibration. <ul style="list-style-type: none"><li>• <b>Gap</b></li><li>• <b>Black Mark</b></li><li>• <b>Continuous</b></li></ul>	
<b>Preprint Calibration</b>	Performs the calibration automatically when using the preprinted labels. <ul style="list-style-type: none"><li>• <b>Gap</b></li><li>• <b>Black Mark</b></li></ul>	

Item	Description	Default
<b>Manual Calibration</b>	<p>If <b>Auto Calibration</b> cannot determine the media type and complete the calibration, it is recommended to use <b>Manual Calibration</b>. After installing the media you want to use, follow the on-screen instructions to complete the calibration.</p> <ul style="list-style-type: none"> <li>• <b>Gap</b></li> <li>• <b>Black Mark</b></li> <li>• <b>Continuous</b></li> </ul>	
<b>Threshold Detect</b>	Sets the sensor's sensitivity. Setting options: Auto / Fixed.	Auto
<b>Maximum Length</b>	Specifies the maximum length for label calibration. Setting range: 1 to 9999 mm.	253
<b>Advanced</b>	<p>Specifies the minimum label length and the maximum gap or black mark length before performing auto-calibration.</p> <ul style="list-style-type: none"> <li>• <b>Min. Paper</b> (Setting range: 0 to 999 mm).</li> <li>• <b>Max. Gap/Mark</b> (Setting range: 0 to 999 mm).</li> </ul>	0

## 8.3 Interface

**Interface** menu allows users to configure the printer's I/O interfaces.

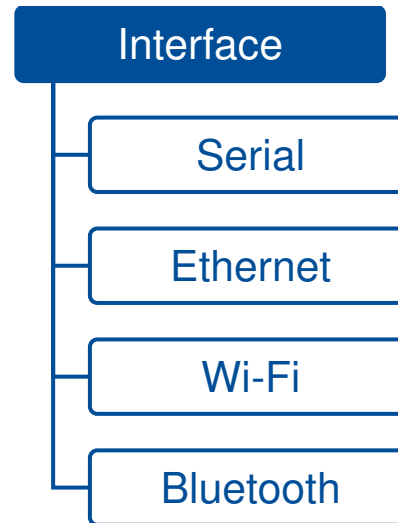

### 8.3.1 Serial

The table below describes the configurable items for the printer's RS-232 interface.

Item	Description	Default
<b>Baud Rate</b>	Sets Baud Rate for the RS-232 interface. Setting options: 1200 / 2400 / 4800 / 9600 / 19200 / 38400 / 57600 / 115200 bps.	9600
<b>Parity</b>	Sets parity check for the RS-232 interface. Setting options: None / Even / Odd.	None
<b>Data Bits</b>	Sets the number of bits in a data frame for the RS-232 interface. Setting options: 7 / 8.	8
<b>Stop Bit</b>	Sets the number of stop bits that mark the end of a frame for the RS-232 interface. Setting options: 1 / 2.	1

### 8.3.2 Ethernet

The table below describes the configurable items for the printer's Ethernet interface.

Item	Description	Default
Status	Displays information about the Ethernet connection if the printer is connected to a wired network.	
Configure	Select to use a DHCP server or non-DHCP server. <ul style="list-style-type: none"><li>• <b>DHCP:</b> Select to use a DHCP server.</li><li>• <b>Static IP:</b> Select to use a non-DHCP server. You need to manually enter the IP address, subnet mask, and default gateway.</li></ul>	DHCP

### 8.3.3 Wi-Fi

The table below describes the configurable items for the printer's Wi-Fi connection.

Item	Description	Default
Network Interface	Sets the network interface. Setting options: Ethernet / Wi-Fi. <b>NOTE:</b> This setting option item will appear when installing a slot-in Wi-Fi module (optional).	Wi-Fi
Status	Displays information about the Wi-Fi connection if the printer is connected to a wireless network.	
Configure	Select to use a DHCP server or non-DHCP server. <ul style="list-style-type: none"><li>• <b>DHCP:</b> Select to use a DHCP server.</li><li>• <b>Static IP:</b> Select to use a non-DHCP server. You need to manually enter the IP address, subnet mask, and default gateway.</li></ul>	DHCP
SSID	Sets SSID for the Wi-Fi connection.	
Security	Sets security type for the Wi-Fi connection.	Open
Password	Sets a password for the Wi-Fi connection.	

### 8.3.4 Bluetooth

The table below describes the configurable items for the Bluetooth interface.

Item	Description	Default
<b>Status</b>	Displays information about the Bluetooth status.	
<b>Local Name</b>	Sets the local name for Bluetooth.	PS-XXXXXX <b>NOTE:</b> XXXXXX indicates the last six digits of the MAC address. You can find the MAC address in the <b>Status</b> item.
<b>PIN Code</b>	Sets the local pin code for Bluetooth. <b>NOTE:</b> This setting item is for MFi module only.	0000

## 8.4 Advanced

The illustration and table below describe the configurable items in the **Advanced** menu.

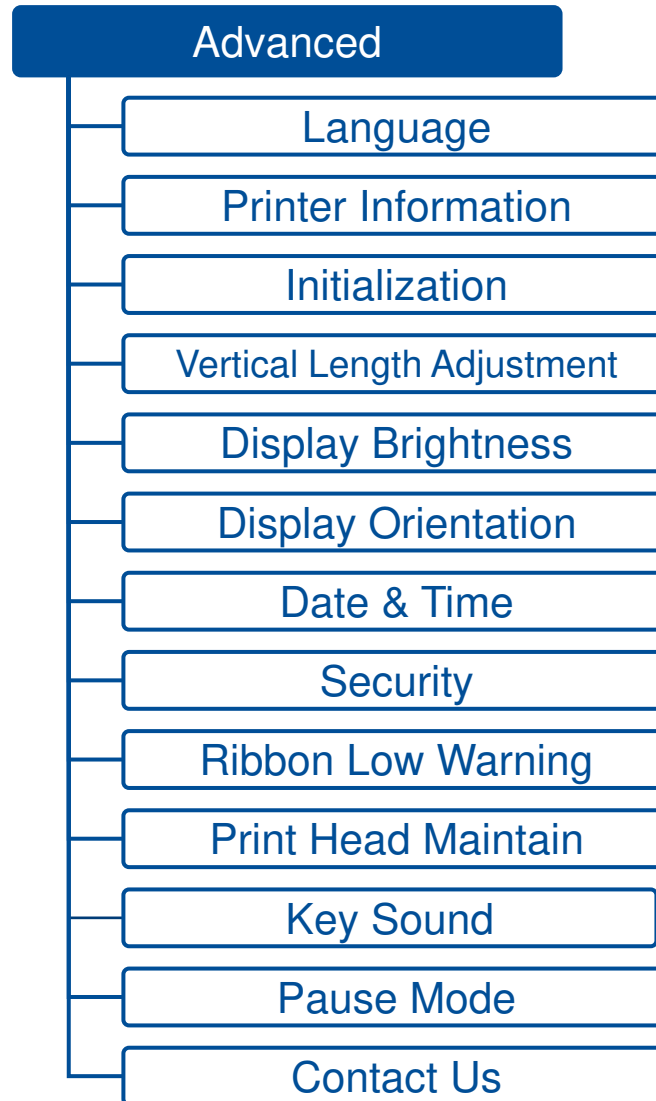

Item	Description	Default
<b>Language</b>	Changes the LCD menu language.	English
<b>Printer Information</b>	Displays printer's information, such as serial number, printhead mileage, the number of printed labels, etc.	
<b>Initialization</b>	Resets the printer to factory default.	
<b>Vertical Length Adjustment</b>	Turns on/off the <b>Vertical Length Adjustment</b> function.	OFF
<b>Display Brightness</b>	Adjusts the brightness for the display. Setting range: 0 to 100.	50
<b>Display Orientation</b>	Adjusts the orientation for the display. Setting options: 0 / 180.	0
<b>Date &amp; Time</b>	Sets the date and time for the printer.	
<b>Security</b>	Sets a password to lock the access to the printer's settings. <ul style="list-style-type: none"> <li>• <b>Menu Lock</b></li> <li>• <b>Menu Password</b></li> </ul>	Disable 8888
<b>Ribbon Low Warning</b>	The printer will release the ribbon low warning message when the remaining ribbon length is less than the configured number of length. Setting range: 10 to 100 mm.	30
<b>Print Head Maintain</b>	Sets how often the printhead should be cleaned. <ul style="list-style-type: none"> <li>• <b>Warning:</b> Turns on/off the notification that reminds users to clean the printhead when the set amount of mileage is fulfilled. Default setting: OFF.</li> <li>• <b>Reset Counter:</b> Resets the mileage count after cleaning the printhead.</li> <li>• <b>Interval:</b> Sets mileage count for the printhead. When the set amount of mileage is fulfilled, the warning icon that reminds users to clean the printhead will appear on the display panel. Default setting: 1 km.</li> </ul>	
<b>Key Sound</b>	Turns on/off the sounds when tapping the touchscreen or pressing the function buttons.	ON
<b>Pause Mode</b>	If <b>Pause Mode</b> is enabled, pressing  will pause the print activities. Setting option: Disable / Enable.	Disable
<b>Contact Us</b>	Displays the contact information about technical support.	

## 8.5 File Manager

**File Manager** allows users to check the remaining space of the printer's built-in memory and manage or execute the files saved in the printer's DRAM, Flash memory, or SD card.

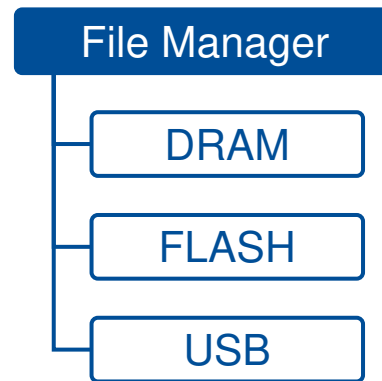

Item	Description
<b>DRAM</b>	Allows users to manage or execute files saved in the printer's DRAM. The executable files must be in .BAS format.
<b>FLASH</b>	Allows users to manage or execute files saved in the printer's Flash memory. The executable files must be in .BAS format.
<b>USB</b>	Allows users to manage or execute files saved in the micro SD card. The executable files must be in .BAS format. <b>NOTE:</b> This item will appear when inserting a storage device into the printer's USB slot.



# 8.6 Diagnostic

The illustration and table below describe the functions in the **Diagnostic** menu.

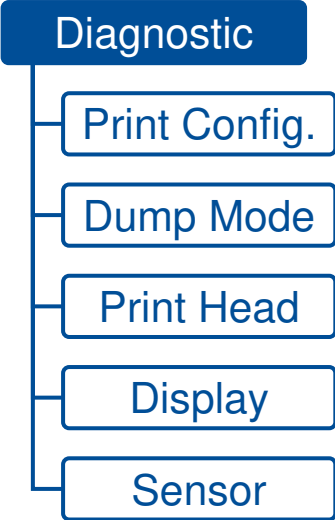

Item	Description
<b>Print Config.</b>	Prints the printer's configurations. You can use this function to check if there is a defective dot on the print heater.

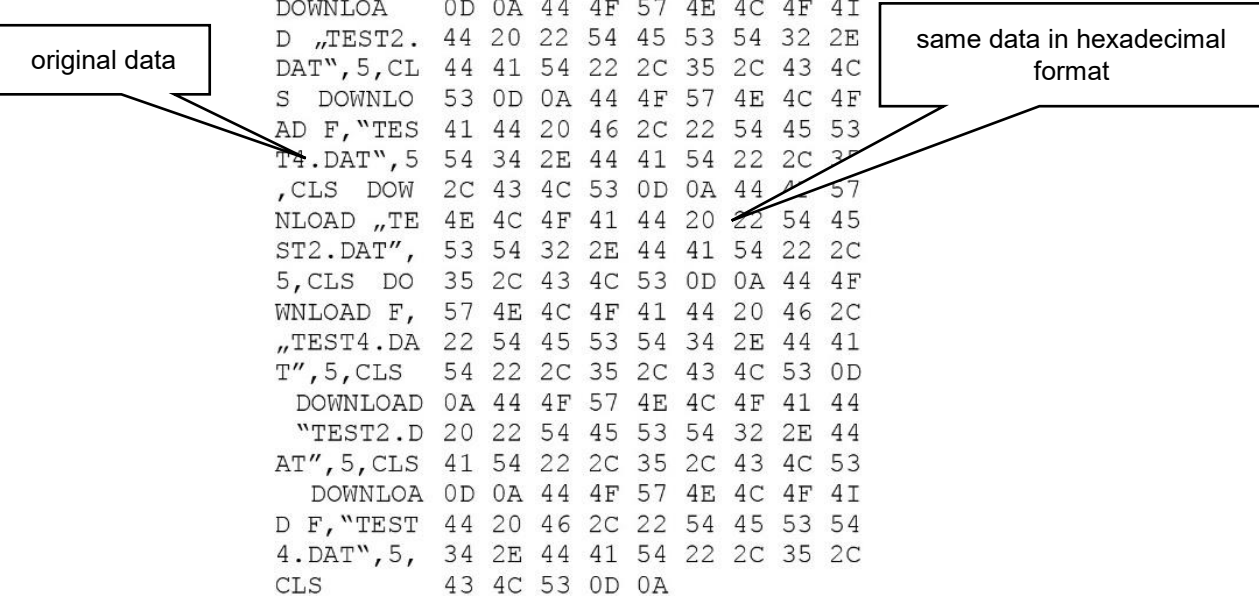
Item	Description
<p style="text-align: center;"><b>Dump Mode</b></p>	<p>In this mode, all received characters will be printed in a two-column format. The left column displays the data which is sent from your computer while the right column shows the same data in the hexadecimal format. This function helps engineers troubleshoot a specific problem.</p> <div style="text-align: center; margin-top: 20px;">  <pre style="font-family: monospace; font-size: 0.9em;"> DOWNLOA 0D 0A 44 4F 57 4E 4C 4F 4I D „TEST2. 44 20 22 54 45 53 54 32 2E DAT“,5,CL 44 41 54 22 2C 35 2C 43 4C S DOWNLO 53 0D 0A 44 4F 57 4E 4C 4F AD F,“TES 41 44 20 46 2C 22 54 45 53 T4.DAT“,5 54 34 2E 44 41 54 22 2C 35 ,CLS DOW 2C 43 4C 53 0D 0A 44 4F 57 NLOAD „TE 4E 4C 4F 41 44 20 22 54 45 ST2.DAT“, 53 54 32 2E 44 41 54 22 2C 5,CLS DO 35 2C 43 4C 53 0D 0A 44 4F WNLOAD F, 57 4E 4C 4F 41 44 20 46 2C „TEST4.DA 22 54 45 53 54 34 2E 44 41 T“,5,CLS 54 22 2C 35 2C 43 4C 53 0D DOWNLOAD 0A 44 4F 57 4E 4C 4F 41 44 “TEST2.D 20 22 54 45 53 54 32 2E 44 AT“,5,CLS 41 54 22 2C 35 2C 43 4C 53 DOWNLOA 0D 0A 44 4F 57 4E 4C 4F 4I D F,“TEST 44 20 46 2C 22 54 45 53 54 4.DAT“,5, 34 2E 44 41 54 22 2C 35 2C CLS 43 4C 53 0D 0A </pre> <p>The diagram shows a two-column output. The left column contains the original data (ASCII characters) and the right column contains the same data in hexadecimal format. A callout box labeled 'original data' points to the first column, and another callout box labeled 'same data in hexadecimal format' points to the second column.</p> </div>
<p style="text-align: center;"><b>Print Head</b></p>	<p>Displays the printhead’s temperature and the amount of the unhealthy dots.</p>
<p style="text-align: center;"><b>Display</b></p>	<p>Checks the LCD’s health status.</p>
<p style="text-align: center;"><b>Sensor</b></p>	<p>Configures the intensity and reading power for the gap sensor, black mark sensor, and ribbon end sensor.</p>

## 8.7 Favorites

**Favorites** provides quick access to the mostly used functions. Follow the steps below to add your mostly used functions into the favorites list:

1. Use the navigation keys to select the item you want to add into the favorites list.

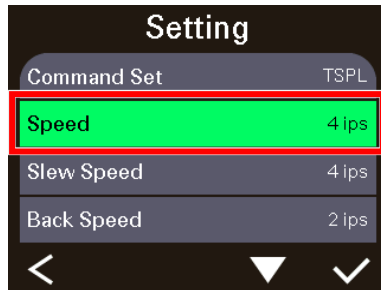

2. Press and hold the right compound key.

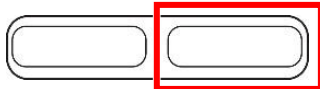

3. When the **Join Favorites** screen is displayed, select **Yes** to add the selected item into the favorites list.

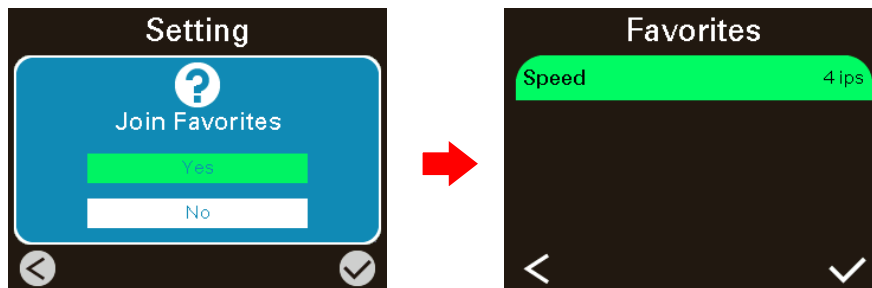

To remove items from the favorites list:

1. When the printer's main screen is displayed, press and hold the left compound key to open the favorites list.

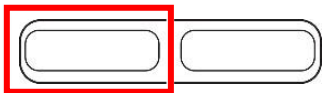
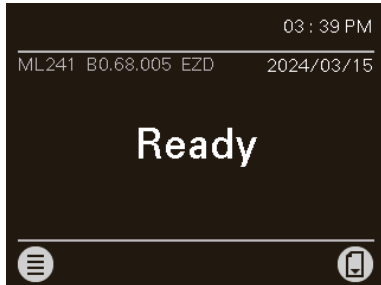

2. When the **Favorites** screen is displayed, use the navigation keys to select the item you want to remove from the list.

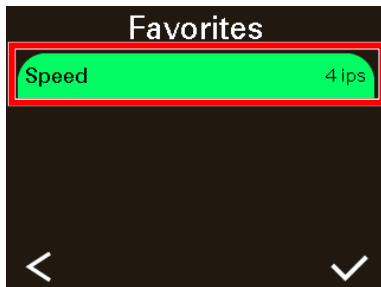

3. Press the hold the right compound key.

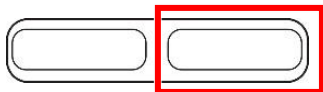

4. When the **Delete Favorites** screen is displayed, select **Yes** to remove the selected item from the list.

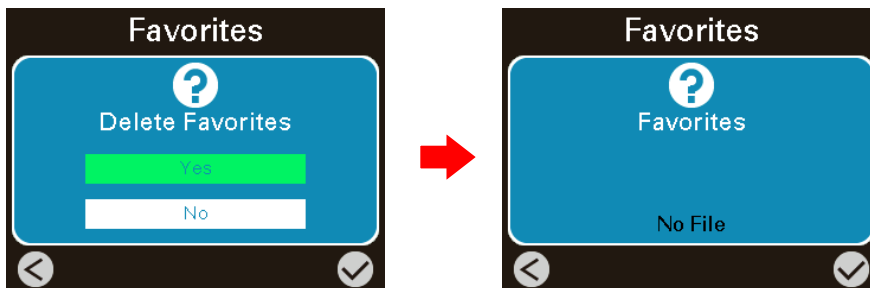

## 9 Troubleshooting

Problem	Possible Cause	Recovery Procedure
<b>Power indicator does not illuminate</b>	<ul style="list-style-type: none"> <li>▪ The power cord is not properly connected.</li> <li>▪ The power switch is closed.</li> </ul>	<ul style="list-style-type: none"> <li>▪ Plug the power cord in printer and outlet.</li> <li>▪ Switch the printer on.</li> </ul>
<b>Carriage Open</b>	The printer carriage is open.	Close the print carriage.
<b>Not Printing</b>	<ul style="list-style-type: none"> <li>▪ Check if interface cable is well connected.</li> <li>▪ Check if wireless or Bluetooth device is well connected.</li> <li>▪ The port in the Windows driver is not correct.</li> </ul>	<ul style="list-style-type: none"> <li>▪ Re-connect cable to interface or change a new cable.</li> <li>▪ Reset the wireless device setting.</li> <li>▪ Select the correct printer port in the driver.</li> <li>▪ Clean the printhead.</li> <li>▪ Printhead's harness connector is not well connected with printhead. Turn off the printer and plug the connector again.</li> <li>▪ Check your program if there is a command - PRINT at the end of the file and there must have CRLF at the end of each command line.</li> </ul>
<b>No print on the label</b>	<ul style="list-style-type: none"> <li>▪ Label or ribbon is loaded not correctly.</li> <li>▪ Use wrong type paper or ribbon</li> </ul>	<ul style="list-style-type: none"> <li>▪ Follow the instructions in loading the media and ribbon.</li> <li>▪ Ribbon and media are not compatible.</li> <li>▪ Verify the ribbon-inked side.</li> <li>▪ The print density setting is incorrect.</li> </ul>
<b>No Ribbon</b>	<ul style="list-style-type: none"> <li>▪ Running out of ribbon.</li> <li>▪ The ribbon is installed incorrectly.</li> </ul>	<ul style="list-style-type: none"> <li>▪ Supply a new ribbon roll.</li> <li>▪ Refer to user's manual to reinstall the ribbon.</li> </ul>
<b>No Paper</b>	<ul style="list-style-type: none"> <li>▪ Running out of label.</li> <li>▪ The label is installed incorrectly.</li> <li>▪ Gap/black mark sensor is not calibrated.</li> </ul>	<ul style="list-style-type: none"> <li>▪ Supply a new label roll.</li> <li>▪ Refer to user's manual to reinstall the label roll.</li> <li>▪ Calibrate the gap/black mark sensor.</li> </ul>
<b>Paper Jam</b>	<ul style="list-style-type: none"> <li>▪ Gap/black mark sensor is not set properly.</li> <li>▪ Make sure label size is set properly.</li> <li>▪ Labels may be stuck inside the printer mechanism.</li> </ul>	<ul style="list-style-type: none"> <li>▪ Calibrate the media sensor.</li> <li>▪ Set media size correctly.</li> <li>▪ Remove the stuck label inside the printer mechanism.</li> </ul>

Problem	Possible Cause	Recovery Procedure
<b>Take Label</b>	Peel function is enabled.	<ul style="list-style-type: none"> <li>▪ If peeler module is installed, please remove the label.</li> <li>▪ If there is no peeler module in front of the printer, please switch off the printer and install it.</li> <li>▪ Check if the connector is plugging correctly.</li> </ul>
<b>Can't downloading the file to memory (FLASH / DRAM/CARD)</b>	The space of memory is full.	Delete unused files in the memory.
<b>Poor Print Quality</b>	<ul style="list-style-type: none"> <li>▪ Ribbon and media is loaded incorrectly.</li> <li>▪ Dust or adhesive accumulation on the printhead.</li> <li>▪ Print density is not set properly.</li> <li>▪ Printhead element is damaged.</li> <li>▪ Ribbon and media are incompatible.</li> <li>▪ The printhead pressure is not set properly.</li> </ul>	<ul style="list-style-type: none"> <li>▪ Reload the supply.</li> <li>▪ Clean the printhead.</li> <li>▪ Clean the platen roller.</li> <li>▪ Adjust the print density and print speed.</li> <li>▪ Run printer self-test and check the printhead test pattern if there is dot missing in the pattern.</li> <li>▪ Change proper ribbon or proper label media.</li> <li>▪ Adjust the printhead pressure adjustment knob.</li> <li>▪ The release lever does not latch the printhead properly.</li> </ul>
<b>Missing printing on the left or right side of label</b>	Wrong label size setup.	Set the correct label size.
<b>Gray line on the blank label</b>	<ul style="list-style-type: none"> <li>▪ The printhead is dirty.</li> <li>▪ The platen roller is dirty.</li> </ul>	<ul style="list-style-type: none"> <li>▪ Clean the printhead.</li> <li>▪ Clean the platen roller. Please refer to <a href="#">Maintenance</a>.</li> </ul>
<b>Irregular printing</b>	<ul style="list-style-type: none"> <li>▪ The printer is in Hex Dump mode.</li> <li>▪ The RS-232 setting is incorrect.</li> </ul>	<ul style="list-style-type: none"> <li>▪ Turn off and on the printer to skip the dump mode.</li> <li>▪ Re-set the RS-232 setting.</li> </ul>
<b>Label feeding is not stable (skew) when printing</b>	The media guide does not touch the edge of the media.	<ul style="list-style-type: none"> <li>▪ If the label is moving to the right side, please move the label guide to left.</li> <li>▪ If the label is moving to the left side, please move the label guide to right.</li> </ul>
<b>Skip labels when printing</b>	<ul style="list-style-type: none"> <li>▪ Label size is not specified properly.</li> <li>▪ Sensor sensitivity is not set properly.</li> <li>▪ The media sensor is covered with dust.</li> </ul>	<ul style="list-style-type: none"> <li>▪ Check if label size is setup correctly.</li> <li>▪ Calibrate the sensor by Auto Gap or Manual Gap options.</li> <li>▪ Clear the GAP/Black mark sensor by blower.</li> </ul>

Problem	Possible Cause	Recovery Procedure
<b>Wrinkle Problem</b>	<ul style="list-style-type: none"> <li>▪ Printhead pressure is incorrect.</li> <li>▪ Ribbon installation is incorrect.</li> <li>▪ Media installation is incorrect.</li> <li>▪ Print density is incorrect.</li> <li>▪ Media feeding is incorrect.</li> </ul>	<ul style="list-style-type: none"> <li>▪ Please refer to <a href="#">Adjustment Knobs</a>.</li> <li>▪ Please set the suitable density to have good print quality.</li> <li>▪ Make sure the label guide touch the edge of the media guide.</li> </ul>
<b>RTC time is incorrect when reboot the printer</b>	The battery has run down.	Check if there is a battery on the main board.
<b>The left side printout position is incorrect</b>	<ul style="list-style-type: none"> <li>▪ Wrong label size setup.</li> <li>▪ The parameter Shift X in LCD menu is incorrect.</li> </ul>	<ul style="list-style-type: none"> <li>▪ Set the correct label size.</li> <li>▪ Press <b>Menu &gt; Setting &gt; Shift X</b> to adjust the parameter of Shift X.</li> </ul>
<b>The printing position of small label is incorrect</b>	<ul style="list-style-type: none"> <li>▪ Media sensor sensitivity is not set properly.</li> <li>▪ Label size is incorrect.</li> <li>▪ The parameter Shift Y in the LCD menu is incorrect.</li> <li>▪ The vertical offset setting in the driver is incorrect.</li> </ul>	<ul style="list-style-type: none"> <li>▪ Calibrate the sensor sensitivity again.</li> <li>▪ Set the correct label size and gap size.</li> <li>▪ Press <b>Menu &gt; Setting &gt; Shift Y</b> to adjust the parameter of Shift Y.</li> <li>▪ Set the vertical offset in the driver if you're using BarTender.</li> </ul>

# 10 Maintenance

This session presents the clean tools and methods to maintain the printer.

## ■ For Cleaning

Depending on the media used, the printer may accumulate residues (media dust, adhesives, etc.) as a by-product of normal printing. To maintain the best printing quality, you should remove these residues by cleaning the printer periodically. Regularly clean the printhead and supply sensors once change a new media to keep the printer at the optimized performance and extend printer life.

## ■ For Disinfecting

Sanitize your printer to protect yourself and others and can help prevent the spread of viruses.

## ■ Important

- Set the printer power switch to O (Off) prior to performing any cleaning or disinfecting tasks. Leave the power cord connected to keep the printer grounded and to reduce the risk of electrostatic damage.
- Do not wear rings or other metallic objects while cleaning any interior area of the printer.
- Use only the cleaning agents recommended in this document. Use of other agents may damage the printer and void its warranty.
- Do not spray or drip liquid cleaning solutions directly into the printer. Apply the solution on a clean lint-free cloth and then apply the dampened cloth to the printer.
- Do not use canned air in the interior of the printer as it can blow dust and debris onto sensors and other critical components.
- Only use a vacuum cleaner with a nozzle and hose that are conductive and grounded to drain off static build up.
- All reference in these procedures for use of isopropyl alcohol requires that a 99% or greater isopropyl alcohol content be used to reduce the risk of moisture corrosion to the printhead.
- Do not touch printhead by hand. If you touch it carelessly, please use 99% Isopropyl alcohol to clean it.
- Always taking personal precaution when using any cleaning agent.





## Cleaning Tools





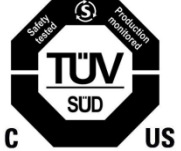

- Cotton swab
- Lint-free cloth
- Brush with soft non-metallic bristles
- Vacuum cleaner
- 75% Ethanol (for disinfecting)
- 99% Isopropyl alcohol (for printhead and platen roller cleaning)
- Genuine printhead cleaning pen
- Mild detergent (without chlorine)

## Cleaning Process:

Printer Part	Method	Frequency
<b>Printhead</b>	(1) Always turn off the printer before cleaning the printhead. (2) Allow the printhead to cool for at least one minute. (3) Use a cotton swab and 99% Isopropyl Alcohol or genuine printhead cleaning pen to clean the printhead surface.	Clean the printhead when changing a new label roll.
<b>Platen Roller</b>	(1) Turn off the printer. (2) Rotate the platen roller and wipe it thoroughly with the lint-free 99% Isopropyl Alcohol.	Clean the platen roller when changing a new label roll.
<b>Peel Bar</b>	Use the lint-free cloth with 99% Isopropyl Alcohol to wipe it.	As needed
<b>Sensor</b>	Use brush with soft non-metallic bristles or a vacuum cleaner, to remove paper dust. Clean upper and lower media sensors to ensure reliable Top of Form and Paper Out sensing.	Monthly
<b>Exterior</b>	Clean the exterior surfaces with a clean, lint-free cloth (water-dampened cloth). If necessary, use a mild detergent or desktop cleaning solution then use the 75% Ethanol to wipe it.	As needed
<b>Interior</b>	Clean the interior of the printer by removing any dirt and lint with a vacuum cleaner, as described above, or use a brush with soft non-metallic bristles then use the 75% Ethanol to wipe it.	As needed

# 11 Agency Compliance and Approvals

	<p>EN 55032, Class A          EN 55035          EN 301489-1,-17          EN 300 328          EN 62311          EN 60950-1</p> <p>This is a class A product. In a domestic environment this product may cause radio interference in which case the user may be required to take adequate measures.</p>
	<p>FCC part 15B, Class A          ICES-003, Class A</p> <p>This equipment has been tested and found to comply with the limits for a Class A digital device, pursuant to Part 15 of the FCC Rules. These limits are designed to provide reasonable protection against harmful interference when the equipment is operated in a commercial environment.</p> <p>This equipment generates, uses, and can radiate radio frequency energy and, if not installed and used in accordance with the manufacturer's instruction manual, may cause harmful interference with radio communications. Operation of this equipment in a residential area is likely to cause harmful interference, in which case you will be required to correct the interference at your own expense.</p> <p>This Class A digital apparatus complies with Canadian ICES-003.          Cet appareil numérique de la classe A est conform à la norme NMB-003 du Canada.</p> <p>This device complies with Part 15 of the FCC Rules. Operation is subject to the following two conditions: (1) This device may cause harmful interference, and (2) this device must accept any interference received, including interference that may cause undesired operation.</p>
	<p>AS/NZS CISPR 32, Class A          AS/NZS 4268          AS/NZS 2772.2</p>
	<p>UL 62368-1          CSA C22.2 No. 62368-1</p>

	<p>EN 62368-1</p>
	<p>KS C 9832 / KS C 983535  이 기기는 업무용(A 급) 전자파적합기기로서 판매자 또는 사용자는 이 점을 주의하시기 바라며, 가정외의 지역에서 사용하는 것을 목적으로 합니다.</p>
	<p>GB 4943.1  GB 9254, Class A  GB 17625.1  此为 A 级产品，在生活环境中，该产品可能会造成无线电干扰，在这种情况下，可能需要用户对干扰采取切实可行的措施。</p>
	<p>Energy Star for Imaging Equipment Version 3.2</p>
	<p>IS 13252(Part 1)/  IEC 60950-1</p>
	<p>CNS 15936 甲類  CNS 15598-1  CNS 15663</p>
	<p>LP0002</p>

**NOTE:** There may have certification differences in the series models, please refer to product label for accuracy.

### **Important safety instructions:**

1. Read all of these instructions and keep them for later use.
2. Follow all warnings and instructions on the product.
3. Disconnect the power plug from the AC outlet before cleaning or if fault happened.  
Do not use liquid or aerosol cleaners. Using a damp cloth is suitable for cleaning.
4. The mains socket shall be installed near the equipment and easily accessible.
5. The unit must be protected against moisture.
6. Ensure the stability when installing the device, Tipping or dropping could cause damage.
7. Make sure to follow the correct power rating and power type indicated on marking label provided by manufacture.
8. Please refer to user manual for maximum operation ambient temperature.

### **WARNING:**

Hazardous moving parts, keep fingers and other body parts away.

### **CAUTION:**

(For equipment with RTC (CR2032) battery or rechargeable battery pack)

Risk of explosion if battery is replaced by an incorrect type.

Dispose of used batteries according to the Instructions as below.

1. DO NOT throw the battery in fire.
2. DO NOT short circuit the contacts.
3. DO NOT disassemble the battery.
4. DO NOT throw the battery in municipal waste.
5. The symbol of the crossed out wheeled bin indicates that the battery should not be placed in municipal waste.



**Caution:** The printhead may be hot and could cause severe burns. Allow the printhead to cool.

**WARNING:**

For operation safety, please turn off the power by the power switch before opening the media cover to load labels, ribbons, or to repair. After completing the steps, please close the media cover first and then turn on the power to start printing.

**CAUTION:**

Any changes or modifications not expressly approved by the grantee of this device could void the user's authority to operate the equipment.

**Below statement are for product with optional RF function.**

**CE Statement:**

This equipment complies with EU radiation exposure limits set forth for an uncontrolled environment. This equipment should be installed and operated with minimum distance 20 cm between the radiator & your body.

All operational modes:

2.4GHz: 802.11b, 802.11g, 802.11n (HT20), 802.11n (HT40)

5GHz: 802.11a

The frequency, mode and the maximum transmitted power in EU are listed below:

2400 MHz – 2483.5 MHz: 19.88 dBm (EIRP)(Wi-Fi)

5150 MHz – 5250 MHz: 17.51 dBm (EIRP)(Wi-Fi)

2402 MHz – 2480 MHz: 6.02 dBm (EIRP)(Bluetooth)

Requirements in AT/BE/BG/CZ/DK/EE/FR/DE/IS/IE/IT/EL/ES/CY/LV/LI/LT/LU/HU/MT/NL/NO/PL/PT/RO/SI/SK/TR/FI/SE/CH/UK/HR.  
5150MHz-5350MHz is for indoor use only.

5150-5350MHz for Only indoor use  
5470-5725MHz for indoor/outdoor use



### Restrictions In AZE

National restrictions information is provided below

Frequency Band	Country	Remark
5150-5350MHz	Azerbaijan	No license needed if used indoor and power not exceeding 30mW
5470-5725MHz		

Hereby, TSC Auto ID Technology Co., Ltd. declares that the radio equipment type [Wi-Fi] IEEE 802.11 a/b/g/n is in compliance with Directive 2014/53/EU

The full text of the EU declaration of conformity is available at the following internet address: <https://www.tscprinters.com>

### Canada, Industry Canada (IC) Notices

This Class B digital apparatus complies with Canadian ICES-003 and RSS-210.

Operation is subject to the following two conditions: (1) this device may not cause interference, and (2) this device must accept any interference, including interference that may cause undesired operation of the device.

### Canada, avis de l'Industry Canada (IC)

Cet appareil numérique de classe B est conforme aux normes canadiennes ICES-003 et RSS-210.

Son fonctionnement est soumis aux deux conditions suivantes : (1) cet appareil ne doit pas causer d'interférence et (2) cet appareil doit accepter toute interférence, notamment les interférences qui peuvent affecter son fonctionnement.

### **NCC 警語:**

經型式認證合格之低功率射頻電機，非經許可，公司、商號或使用者均不得擅自變更頻率、加大功率或變更原設計之特性及功能。(即低功率電波輻射性電機管理辦法第十二條)

低功率射頻電機之使用不得影響飛航安全及干擾合法通信；經發現有干擾現象時，應立即停用，並改善至無干擾時方得繼續使用。

前項合法通信，指依電信法規定作業之無線電通信。低功率射頻電機須忍受合法通信或工業、科學及醫療用電波輻射性電機設備之干擾。(即低功率電波輻射性電機管理辦法第十四條)

### **BSMI Class A 警語:**

這是甲類的資訊產品，在居住的環境使用中時，可能會造成射頻干擾，在這種情況下，使用者會被要求採取某些適當的對策。

### **MFi for Bluetooth**



Use of the Made for Apple badge means that an accessory has been designed to connect specifically to the Apple product(s) identified in the badge, and has been certified by the developer to meet Apple performance standards. Apple is not responsible for the operation of this device or its compliance with safety and regulatory standards.

### For US Model

Made for iPhone®XS Max, iPhone XS, iPhone XR, iPhone X, iPhone 8, iPhone 8 Plus, iPhone 7, iPhone 7 Plus, iPhone SE, iPhone 6s, iPhone 6s Plus, iPhone 6, iPhone 6 Plus, iPhone 5s, iPad Pro® 12.9-inch (2nd generation), iPad Pro 10.5-inch, iPad® (6th generation), iPad (5th generation), iPad Pro 9.7-inch, iPad Pro 12.9-inch (1st generation), iPad Air® 2, iPad mini™ 4, iPad mini 3, iPad Air, iPad mini 2, iPod touch® (6th generation)

iPad, iPad Air, iPad Pro, iPhone are trademarks of Apple Inc., registered in the U.S. and other countries.

#### For JP Model

Made for iPhone XS Max, iPhone XS, iPhone XR, iPhone X, iPhone 8, iPhone 8 Plus, iPhone 7, iPhone 7 Plus, iPhone SE, iPhone 6s, iPhone 6s Plus, iPhone 6, iPhone 6 Plus, iPhone 5s, iPad Pro 12.9-inch (2nd generation), iPad Pro 10.5-inch, iPad (6th generation), iPad (5th generation), iPad Pro 9.7-inch, iPad Pro 12.9-inch (1st generation), iPad Air 2, iPad mini 4, iPad mini 3, iPad Air, iPad mini 2, iPod touch (6th generation)

iPad, iPad Air, iPad Pro, iPhone are trademarks of Apple Inc., registered in the U.S. and other countries. The trademark “iPhone” is used in Japan with a license from Aiphone K.K.

#### Except for US, JP Model

Made for iPhone XS Max, iPhone XS, iPhone XR, iPhone X, iPhone 8, iPhone 8 Plus, iPhone 7, iPhone 7 Plus, iPhone SE, iPhone 6s, iPhone 6s Plus, iPhone 6, iPhone 6 Plus, iPhone 5s, iPad Pro 12.9-inch (2nd generation), iPad Pro 10.5-inch, iPad (6th generation), iPad (5th generation), iPad Pro 9.7-inch, iPad Pro 12.9-inch (1st generation), iPad Air 2, iPad mini 4, iPad mini 3, iPad Air, iPad mini 2, iPod touch (6th generation)

iPad, iPad Air, iPad Pro, iPhone are trademarks of Apple Inc., registered in the U.S. and other countries.



限用物質及其化學符號 Restricted substances and its chemical symbols						
	鉛Lead (Pb)	汞Mercury (Hg)	鎘Cadmium (Cd)	六價鉻Hexavalent chromium (Cr <sup>+6</sup> )	多溴聯苯 Polybrominated biphenyls (PBB)	多溴二苯醚 Polybrominated diphenyl ethers (PBDE)
內外塑膠件	○	○	○	○	○	○
內外鐵件	-	○	○	○	○	○
滾輪	○	○	○	○	○	○
銘版	○	○	○	○	○	○
電路板	-	○	○	○	○	○
晶片電阻	-	○	○	○	○	○
積層陶瓷表面黏著 電容	○	○	○	○	○	○
集成電路-IC	-	○	○	○	○	○
電源供應器	○	○	○	○	○	○
印字頭	-	○	○	○	○	○
馬達	-	○	○	○	○	○
液晶顯示器	-	○	○	○	○	○
插座	-	○	○	○	○	○
線材	-	○	○	○	○	○

備考 1. “超出 0.1 wt %” 及 “超出 0.01 wt %” 係指限用物質之百分比含量超出百分比含量基準值。  
Note 1 : “Exceeding 0.1 wt %” and “exceeding 0.01 wt %” indicate that the percentage content of the restricted substance exceeds the reference percentage value of presence condition.

備考 2. “○” 係指該項限用物質之百分比含量未超出百分比含量基準值。  
Note 2 : “○” indicates that the percentage content of the restricted substance does not exceed the percentage of reference value of presence.

備考 3. “-” 係指該項限用物質為排除項目。  
Note 3 : The “-” indicates that the restricted substance corresponds to the exemption.

# Revision History

Date	Description	Technical Writer
2024/05/08	Official release.	Peter Yao



[www.tscprinters.com](http://www.tscprinters.com)